

tech  rack  
tech tray™



**WORKPIECE CARRIERS & CLEANING RACKS FOR INDUSTRIAL APPLICATIONS**

**FLEXIBLE, SAFE and EFFICIENT**

EN

## CONTENTS

---

### Advantages

FRIES workpiece carriers and cleaning racks at a glance

Page 3 - 13

---



tech-rack variogrid

Page 14 - 25

---

---



techtray

Page 26 - 37

---

---



tech-rack custom<sup>+</sup>

Page 40 - 47

---



tech-rack custom

Page 48 - 59

---



tech-rack

Page 60 - 73

---



Workpiece carrier systems  
All advantages at a glance

[www.fries-kt.com](http://www.fries-kt.com)

---

# There is method in our innovation

»Workpiece carriers and cleaning racks - flexible all-in-one systems for industrial applications - convince in logistics, cleaning and storage.«

In sensitive industries, such as metal processing, optics, medical technology, mechatronics, microelectronics or precision engineering, the cleaning of components is a central part of many production and assembly processes. In this context, specific workpiece carriers and cleaning racks are used to fix workpieces in a certain position and at certain points to achieve optimum cleanliness.

## FRIES workpiece carriers

**tech-rack variogrid – THE FLEXIBLE ONE**

Secure positioning of highly complex parts



**techtray – THE VERSATILE ONE**

In standard rack/compartiment rack or as separate workpiece carrier



## FRIES cleaning racks

**tech-rack custom+ – THE VARIABLE SOLUTION**

Specially designed for use in automated production processes



**NEW**

**tech-rack custom – INDUSTRY 4.0**

Developed for automated manufacturing processes



**tech-rack – THE ADAPTABLE ONE**

Individual height adjustment, convertible for other partition dimension



## All-in-one systems for industrial application

» Gentle transport

» Secure storage

» Perfect cleaning

Everything consistently in one system



CLEANING



TRANSPORT



STORAGE

# Advantages of workpiece carriers and cleaning racks

"Perfect solutions for your requirements"

Besides the specific product advantages described in detail as of page 14, all FRIES workpiece carriers and cleaning racks specially designed for cleaning, transport and storage of sensitive components offer the following advantages:



## Plastic instead of stainless steel

- » Optimum protection against dents and scratches at components
- » Reduced scrap



## Plastic meets high demands

- » For challenging thermal and chemical requirements in standard industrial cleaning of components
- » Perfectly suited for aqueous and solvent-based procedures and ultrasound applications
- » No migration of plastic



## Cost reduction thanks to process optimisation

- » All-in-one: reduced repackaging of components between production, cleaning, storage and assembly including transport



Workpiece carrier systems  
All advantages at a glance

[www.fries-kt.com](http://www.fries-kt.com)

### Further advantages of FRIES systems

» **Numerous individual configuration options**

Modular system for easy conversion for different component geometries, stackable.

» **Optimum protection and safety**

No clamping or mounting of components necessary - contact only with plastic, no dents and scratches at components and reduced scrap.

» **Efficient cleaning with optimised accessibility**

High cleanliness, good drying of components and removal of residual cleaning agents thanks to optimised openings and smooth shapes at the system. Smooth shapes enable optimum draining of water without separate cleaning of empty fittings.

» **Low weight**

Workpiece carriers and cleaning racks made of plastic have a lower weight than comparable metal racks and plates.

» **Automation capability**

Reduction of personnel costs.

» **Reuse system**

Reusable workpiece carriers and cleaning racks replace previous single-use blister packaging for saving of valuable resources and protection of the environment.

» **Uncomplicated and safe handling**

Reduced risk of injury thanks to smooth edges, easy assignment thanks to logic marking, installation without tools.

## Plastic, the proven alternative to metal

FRIES materials in detail:

### COMP 13/14 material

FRIES Comp 13/14 was designed for basic requirements in industrial component cleaning and is suitable for cleaning processes with aqueous and solvent-based media and ultrasound applications.



### COMP 21/22 material

FRIES Comp 21/22 offers the advantage of even higher chemical and thermal resistance and, therefore, meets higher requirements in industrial component cleaning. This also enables the use in autoclaves for vapour sterilisation.

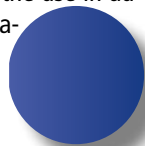

### COMP 25 (ESD) material

FRIES Comp 25 offers protection of sensitive electronic components against electrostatic discharge. Generation of electrostatic charges is prevented and already existing charges are safely discharged.



# Product range at a glance

## »Workpiece carriers and cleaning racks for industrial component cleaning«

FRIES tech-rack models can be used to safely and easily clean, store and transport sensitive high-quality components. All this in just one rack without repackaging. This enables an increase in efficiency and cost reduction to gain competitive advantage.

### tech-rack variogrid workpiece carrier

#### "Tailored to your requirements"

Basic dimensions 600 x 400 mm – can be individually cut to size

Materials depending on requirements (see page 5):



Comp 13/14

Comp 21/22

Comp 25 (ESD)

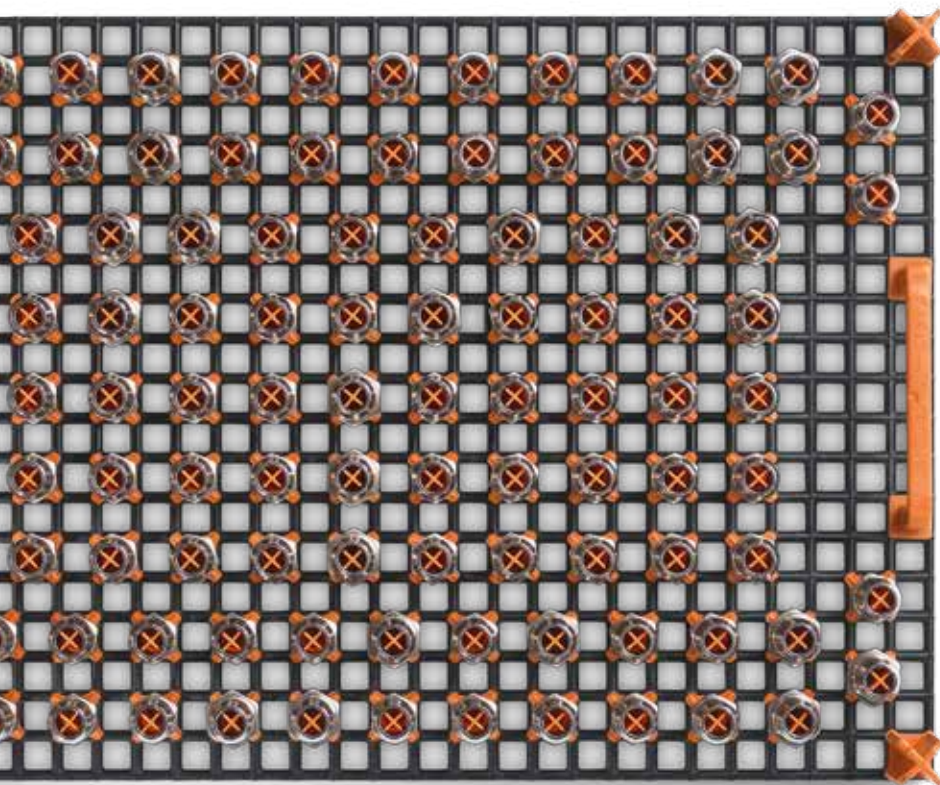

#### Advantages

- » Variable plate size: The plate can be cut to the required size
- » Optimum use of surface and high level of protection of components (9 mm grid)
- » Suitable for full automation
- » Modular attachment of handles for more efficient space use
- » ESD-compatibility (entering ESD protection zones with the same workpiece carrier for assembly)
- » Dividers plugged into the bottom counter the capillary effect

## techtray workpiece carrier

»Suitable for a wide range of application«

425 x 276 mm – Schäfer 2 format

Materials depending on requirements (see page 5):



Comp 13/14

Comp 21/22

Comp 25 (ESD)

### Advantages

- » Basic plate in "Schäfer-2 format"
- » Optimum use of surface and high level of protection of components (9 mm grid)
- » Suitable for full automation
- » Recessed grip at the plate (no additional space required)
- » Combinable with tech-rack variogrid
- » ESD-compatibility (entering ESD protection zones with the same workpiece carrier for assembly)
- » Dividers plugged into the bottom counter the capillary effect

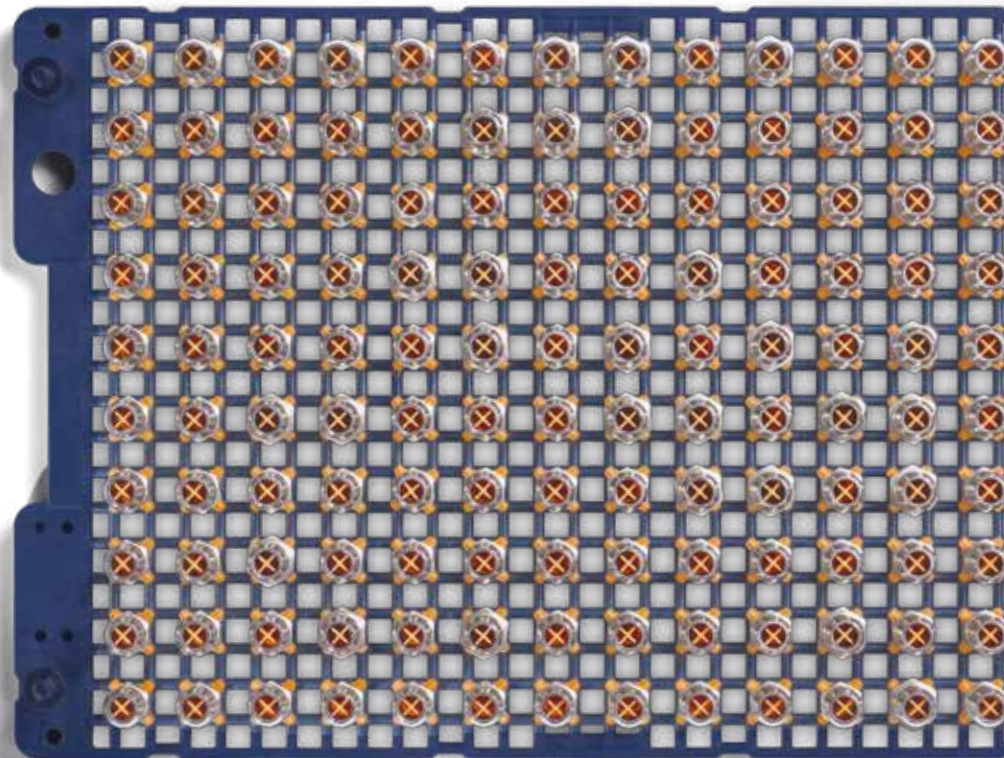

## tech-rack custom<sup>+</sup> cleaning rack

### "Versatile use for automated handling"

400 x 300 mm – available with standard variogrid base or with customised grid base

Material (see page 5):



Comp 21/22

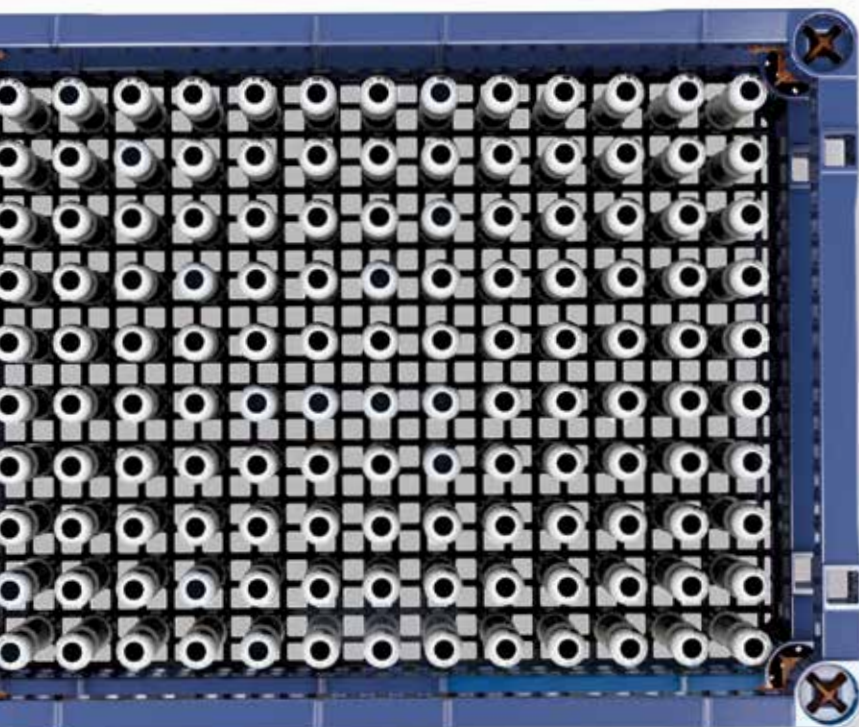

### Advantages

- » Designed for complete automation
- » Component-related grid base available (components can be positioned without any pins or dividers)
- » Automated loading, unloading and stacking thanks to gripper arms
- » Angled stacking edge and dividers integrated into the base counteract the capillary effect
- » Optionally available with recessed grips
- » High load capacity
- » RFID chip available on request
- » Rounded corners offer protection against damage

## tech-rack custom cleaning rack

»The right rack for full automation and robotic handling«

600 x 400 mm – available with variogrid standard bottom or individual grid bottom

Material (see page 5):



Comp 21/22

### Advantages

- » Designed for full automation
- » Component-tailored grid bottom available (component positioning without pin or divider)
- » Automatic loading and unloading as well as stacking by means of grippers possible
- » Inclined stacking edge and secured dividers plugged into the bottom counter the capillary effect
- » High load-bearing capacity
- » RFID chip available on request
- » Smooth corners provide protection from damage

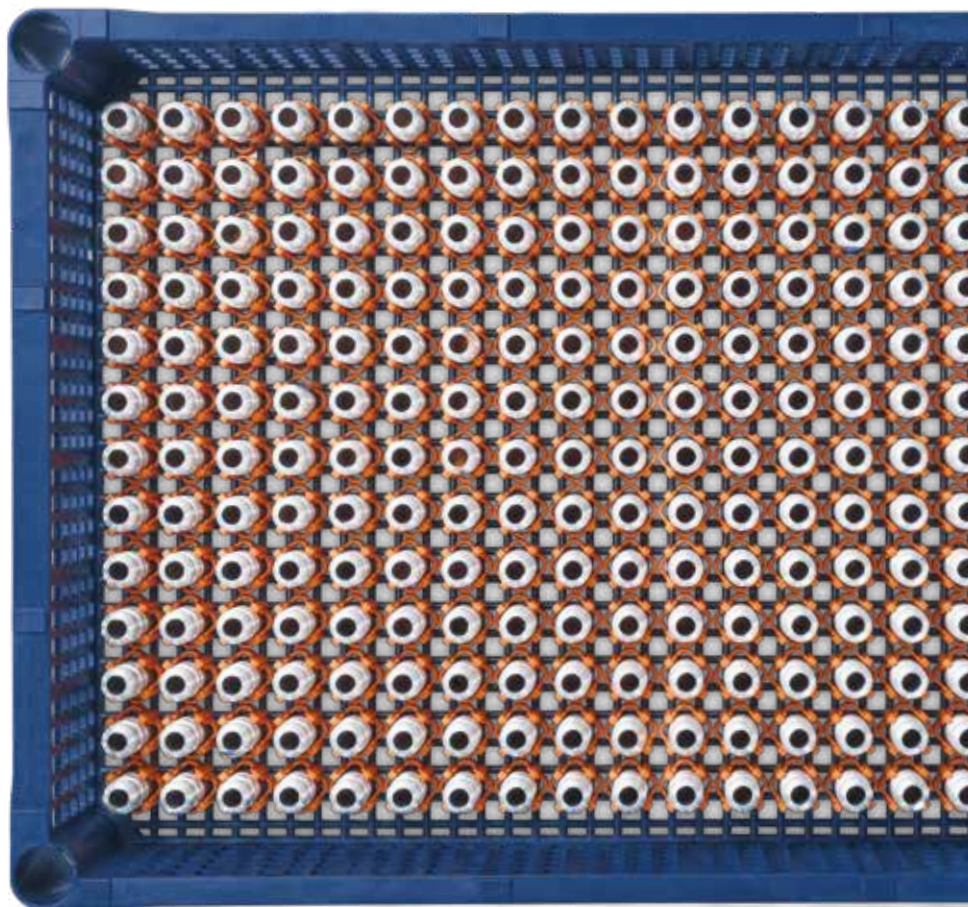

## tech-rack cleaning rack

### "The adaptable all-rounder"

600 x 400 mm – modular design

Materials depending on requirements (see page 5):



Comp 13/14

Comp 21/22

### Advantages

- » Modular design: for adaptation to component geometries
- » Height adjustment with millimetre precision
- » Optimum use of surface and high level of protection of components (15 mm grid)
- » High load-bearing capacity
- » Safe and secure: Openings in cleaning racks can be closed individually by means of smart side panels
- » Dimensions suitable for EURO pallets and other stacking systems (KLT Euro containers, etc.).

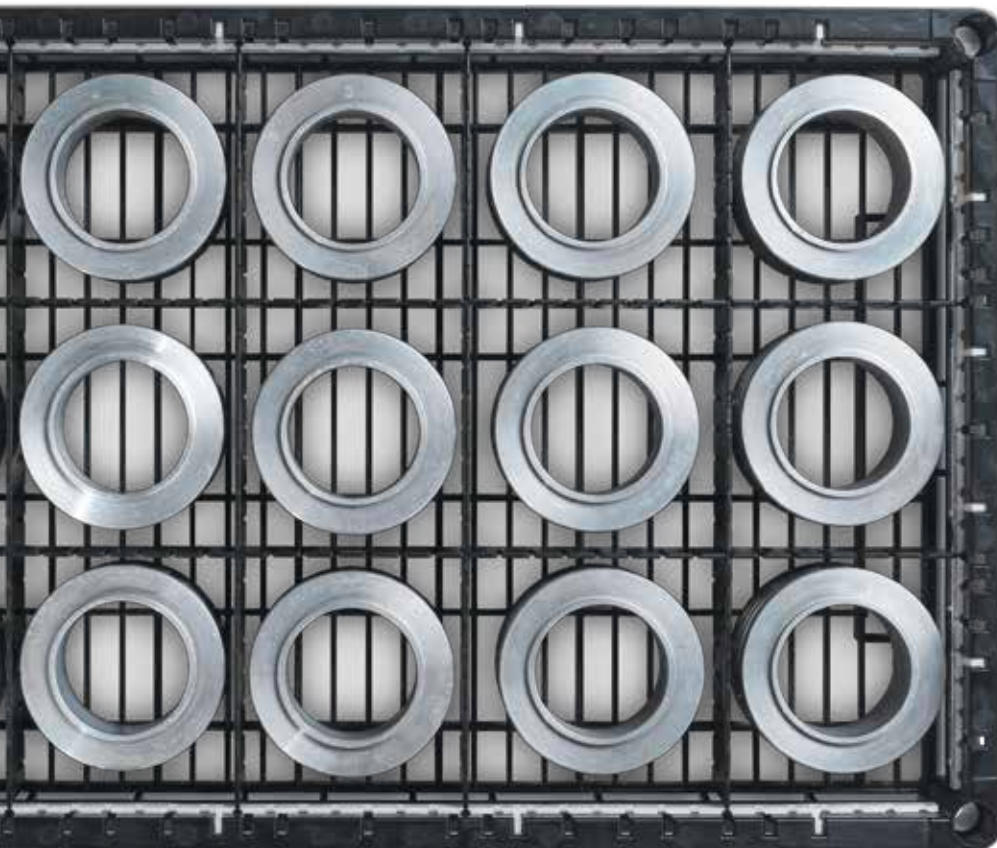

## Rotary pin variety

**"Numerous pins available"**

For the precise positioning of components.  
Customer-specific configurations are possible.



# Comprehensive process chain in industrial manufacturing of components

## »Example for a potential production process«

In all fields of industrial manufacturing of components, raw components run through numerous process steps until the product is finished. Between the individual steps, the workpiece must always be cleaned from impurities.

Such impurities may include chipping, oil or grease (particular impurities) or adhesives, solder or welding residues (surface film of impurities). If fine particles and impurities are not removed, the following production steps may be disturbed compromising or hindering the function of the component.

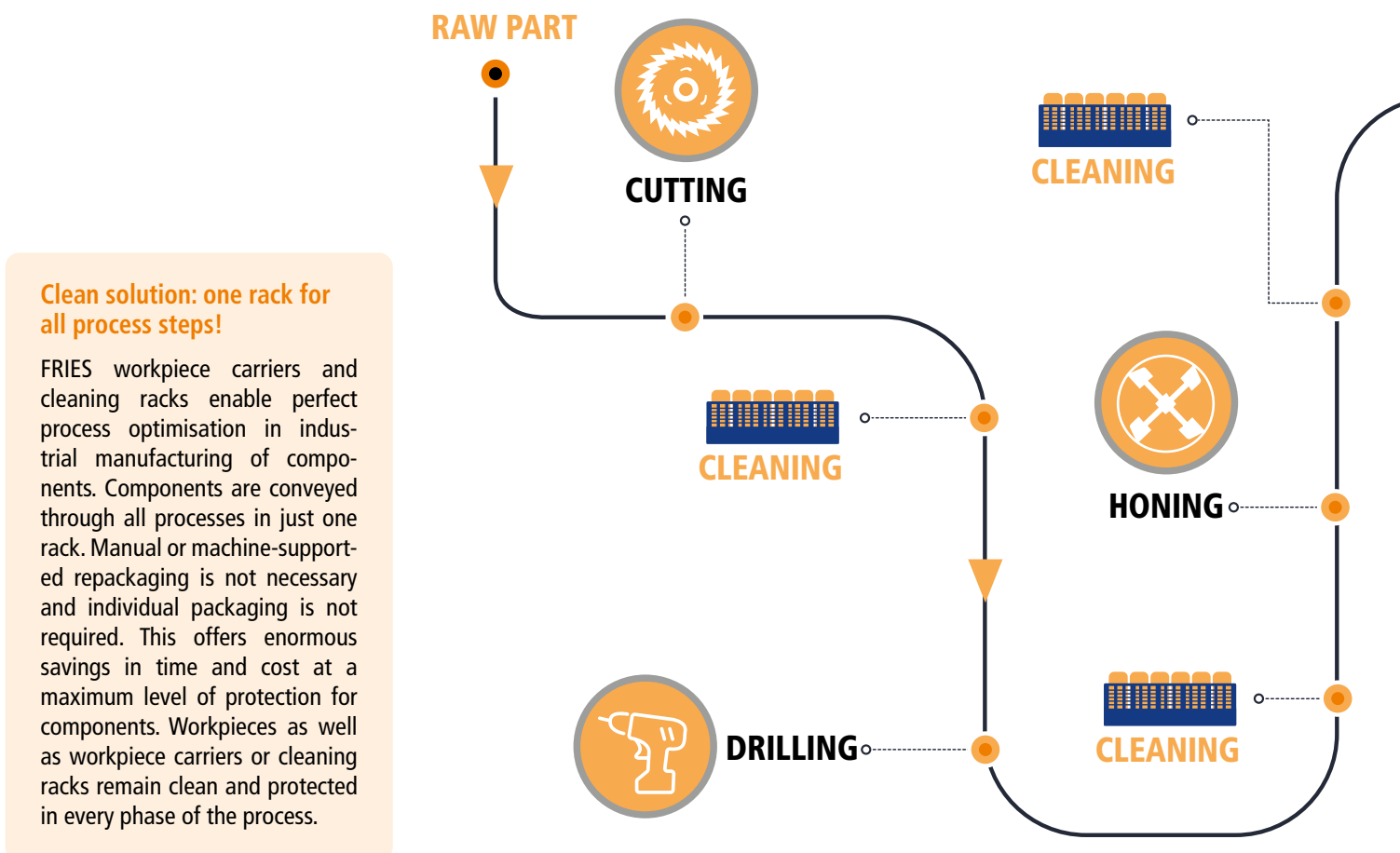

### Clean solution: one rack for all process steps!

FRIES workpiece carriers and cleaning racks enable perfect process optimisation in industrial manufacturing of components. Components are conveyed through all processes in just one rack. Manual or machine-supported repackaging is not necessary and individual packaging is not required. This offers enormous savings in time and cost at a maximum level of protection for components. Workpieces as well as workpiece carriers or cleaning racks remain clean and protected in every phase of the process.

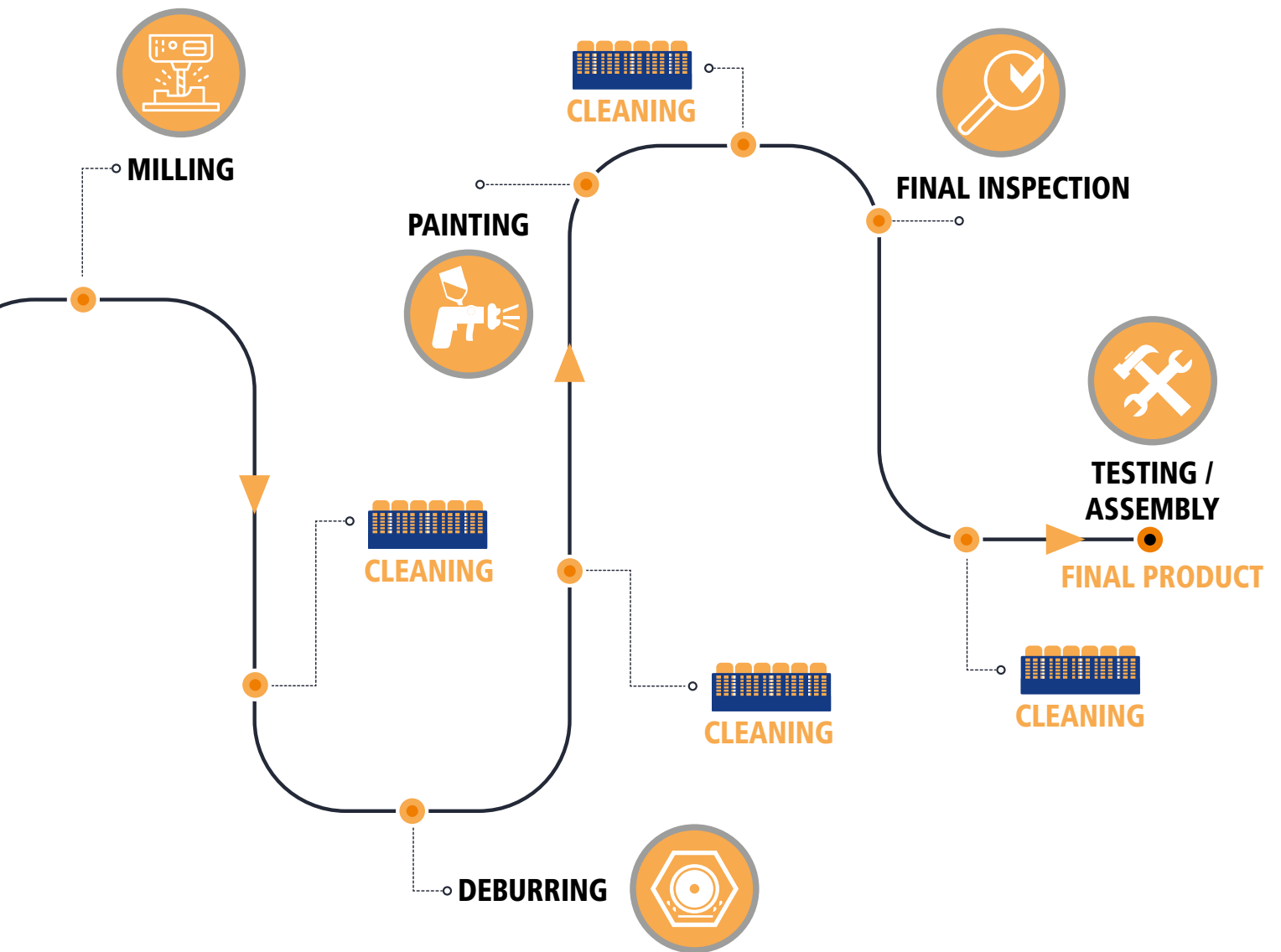

# Industry 4.0 – networked production

## »tech-rack custom cleaning rack«

The entire logistic in production is in transition: Intelligent machinery, storage systems and equipment are fully connected via IT solutions for intercommunication. And this is the case through the entire value chain from storage over production down to logistics.

Automation and robotization respectively also increase the requirements for cleaning racks and workpiece carriers in the fields of cleaning, transportation and storage. FRIES Kunststofftechnik has developed a cleaning rack that is the perfect solution for automated manufacturing processes.



## 4. Automated palletisation of cleaning racks

3. Automated cleaning  
in the cleaning system



2. Automated loading of workpieces into  
cleaning racks



1. Automated handling of  
cleaning racks

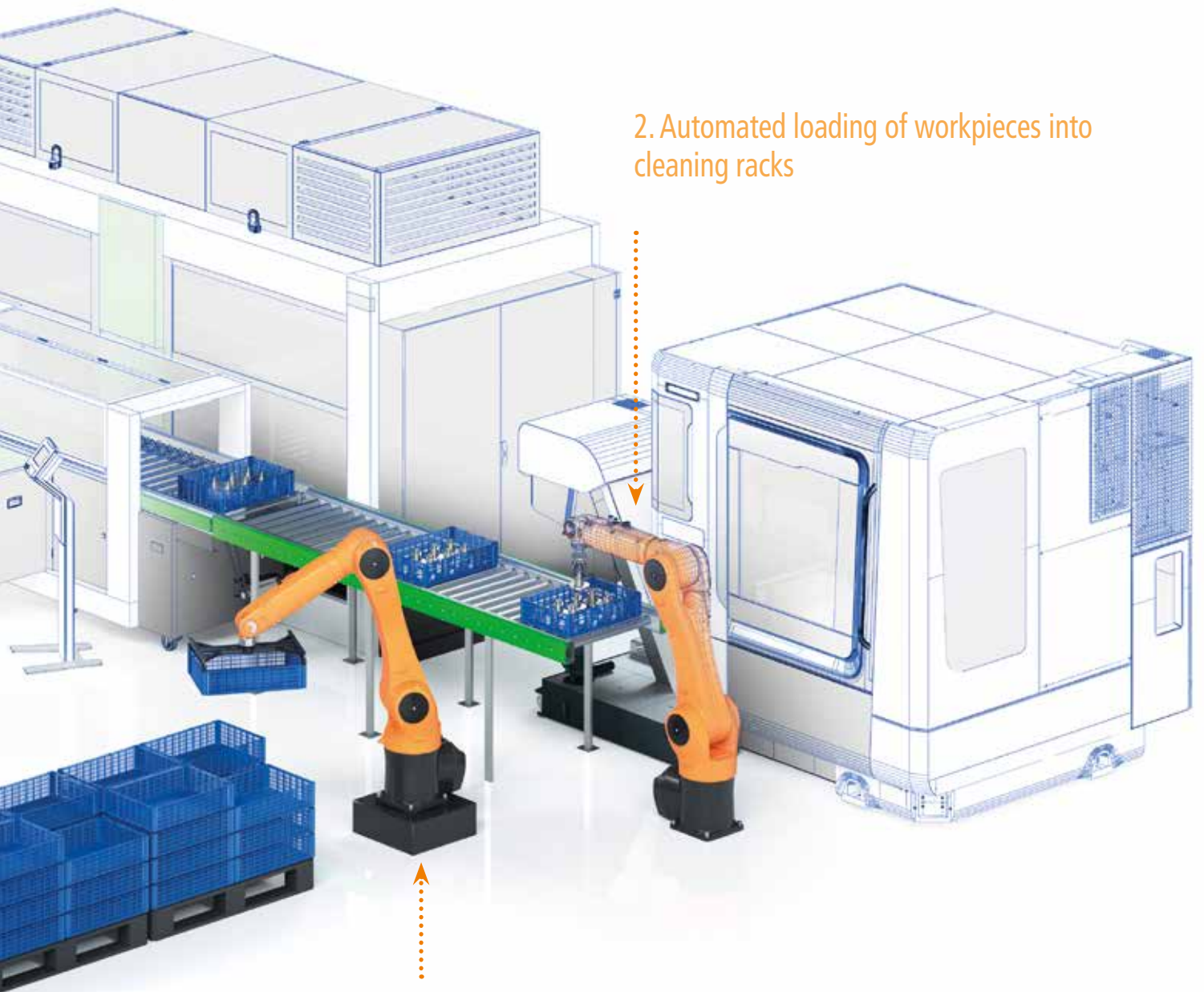

## **TECH-RACK VARIOGRID WORKPIECE CARRIER 600 X 400**

---

**THE FLEXIBLE ONE** secure positioning of high-complexity small parts

---

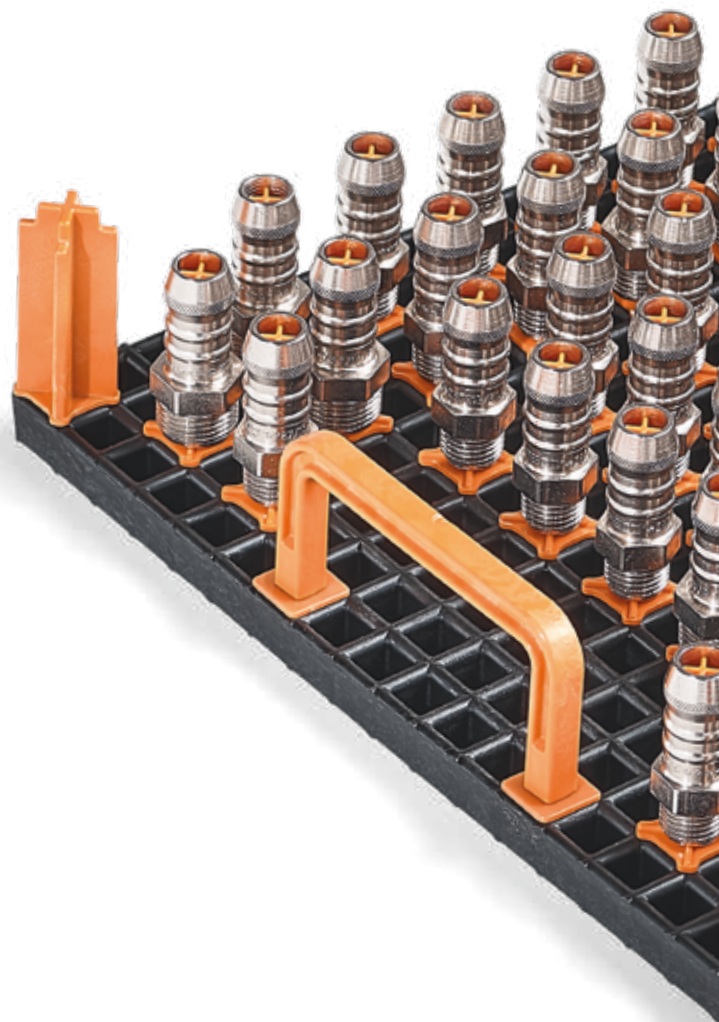

# tech-rack variogrid workpiece carrier

»tech-rack variogrid - flexible all-in-one systems for the industry.  
The flexible workpiece carriers from FRIES for logistics, cleaning and storage.«

The tech-rack variogrid workpiece carrier offers a high level of efficiency and considerable cost reductions in logistics and cleaning of sensitive metal parts. Workpiece carrier plates can be individually cut to the required size and thus adjusted to the requirements of the cleaning machine or also for storage in small load carriers (SLC). To ensure that they can be stacked at any size, the rotating stacking bolts can be placed on the grid plate. This can be used to safely and easily clean, store and transport sensitive high-quality components. All in one workpiece carrier, without repositioning and repackaging.

Materials depending on requirements: (see page 5)



Comp 13/14



Comp 21/22



Comp 25

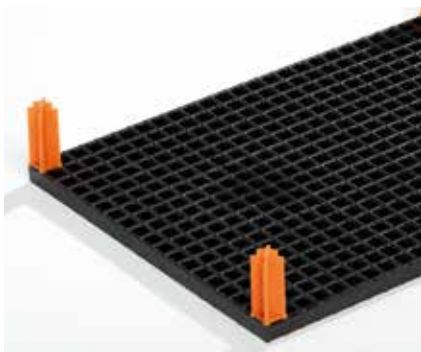

## Variable plate size

The tech-rack variogrid plate can be cut to the required size to meet individual process conditions. The workpiece carriers can be stacked easily by means of rotating stacking bolts.

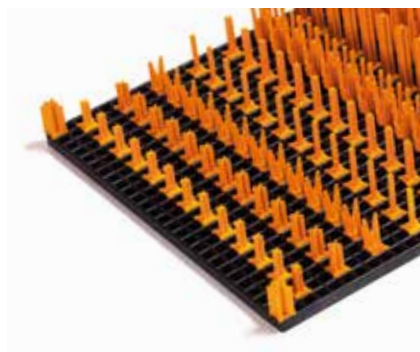

## Optimised surface and scratch protection

Rotating and plug pins can be flexibly mounted on the modular variogrid workpiece carrier system without any tools. Components are precisely and securely positioned and protected against dents and scratches.



## Quick and flexible adjustment of partitions with dividers

The variogrid plate enables longitudinal and cross adjustment within a 9 mm grid. Divider heights of 28, 42, 69 and 96 mm are available. Inside the partitions, components are perfectly protected.

## Examples of use

### Numerous rotating and plug pins

Many rotating and plug pins for shafts, sleeves, turned parts, milled parts and many more are available to precisely position the components on the variogrid base plate. On request, rotating pins can also be manufactured individually to suit the component.



## Variety of fastening options

The tech-rack variogrid press-fit bases ensure a large variety of fastening options. In this way, threads, screws, hooks or handles can be mounted on the base plate easily.

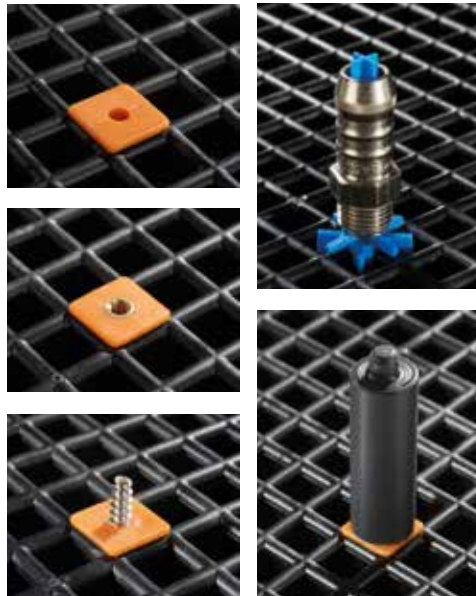

## Maximum variability & flexibility

The variogrid rotating stacking bolts and rotating pins can be mounted on the base plate in any way and can also be adapted subsequently. This means, the stackability is ensured irrespective of the plate size.

## Easy assembly



1. Plugging in

2. Rotating

3. Ready to placing or stacking

### Further advantages

- » Suitable for full automation and robotic handling
- » Uncomplicated and quick installation
- » Handles enable modular attachment for optimum use of space on the workpiece plate
- » Dividers plugged into the bottom counter the capillary effect
- » ESD-compatibility (entering ESD protection zones with the same workpiece carrier for assembly)
- » Numerous configuration options enable fitting of a maximum variety of components

## References

### HAAG-STREIT AG Koeniz (CH)

The leading manufacturer of slit lamps relies on the tech-rack variogrid workpiece carriers over the entire process from the lathe to assembly. The workpiece carriers are fitted at the lathe and cleaned in the chamber unit. The main focus is on maximum efficiency when it comes to removal of particles and surface cleaning. Afterwards, the workpiece carriers are conveyed in Euroboxes to assembly.



### SENSOR COMPANY (CH)

In companies producing sensor technology, the tech-rack variogrid workpiece carriers are used from the turning and milling centre to the storage. A clear identification ensures that the workpiece carrier is inserted in the magazine using the correct compartment subdivision, because the turning and milling centre produces overnight by means of automation thanks to 48 different workpiece carriers which are equipped using the robot.





### Haag-Streit AG, Koeniz (CH)

#### Stefan Oetliker



"Thanks to tech-rack variogrid, damaging of components can be prevented (dents and scratches). Additionally, we reduce our process costs by easier handling".



### FRENCKEN MECHATRONICS B.V. Eindhoven (NL)

Frencken develops, designs and manufactures individual components by order of the customer, but also entire machines and systems for the field of medicine and research. Their customers include companies, such as ASML, Philips Medical Systems, Bruker and Thermo Fisher Scientific. Developing and manufacturing for the high-tech sector also means meeting the highest cleaning requirements. Frencken uses the latest plant technology in which the tech-rack variogrid system is employed. The flexible workpiece carrier ensures optimum cleaning, offers maximum protection of the sensitive surfaces and enables a safe transport of the components.

## The system components: Material Comp 13/14

The material type Comp 13/14 was designed for basic requirements in industrial component cleaning and is suitable for cleaning processes with aqueous and solvent-based media and ultrasound applications.

### tech-rack variogrid workpiece carrier plate

Basic dimensions 600 x 400 mm, height 13 mm  
The plate can be cut to individual sizes.  
(see page 24)



### Top frame low

600 x 400 mm, height 36 mm,  
combinable with tech-rack variogrid and  
tech-rack cleaning racks



### Top frame high

600 x 400 mm, height 63 mm,  
combinable with tech-rack variogrid and  
tech-rack cleaning racks



Example of application: variogrid base plate with frame, ensures combination with tech-rack racks



### Dividers

Adapted to respective plate size, enable partitions fitting  
the size of the workpieces  
Available in heights of 28, 42, 69 and 96 mm



Lengths: 272 mm / 376 mm / 558 mm

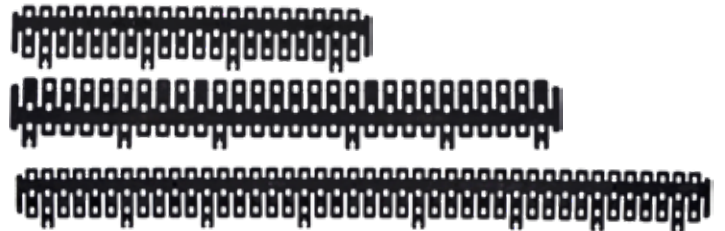

Lengths: 272 mm / 376 mm / 558 mm

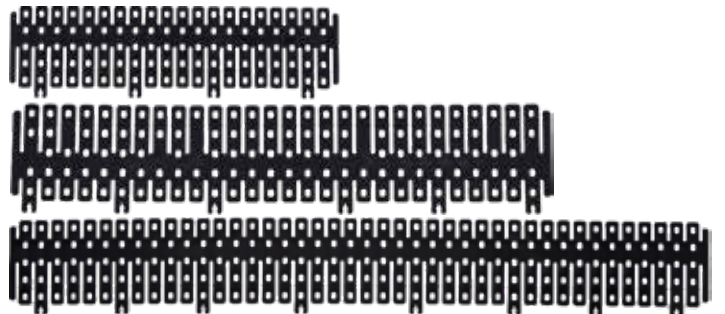

Lengths: 272 mm / 376 mm / 558 mm

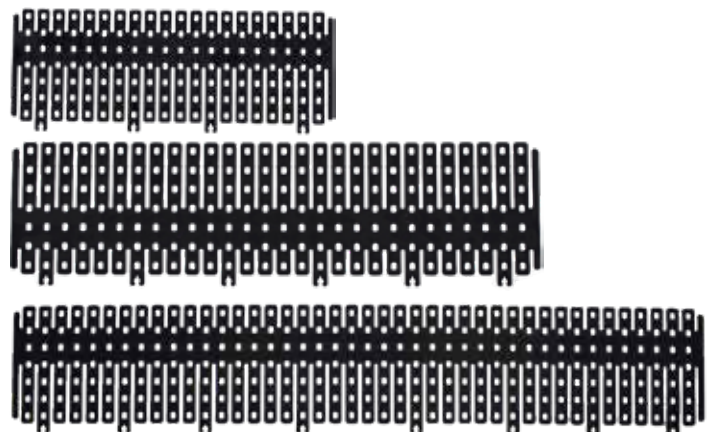

Lengths: 272 mm / 376 mm / 558 mm

## The system components: Material Comp 21/22

The material type Comp 21/22 offers the advantage of even higher chemical and thermal resistance and meets higher requirements in industrial component cleaning.

### tech-rack variogrid workpiece carrier plate

Basic dimensions 600 x 400 mm, height 13 mm  
The plate can be cut to individual sizes.  
(see page 24)



### Top frame low

600 x 400 mm, height 36 mm,  
combinable with tech-rack variogrid and  
tech-rack cleaning racks



### Top frame high

600 x 400 mm, height 63 mm,  
combinable with tech-rack variogrid and  
tech-rack cleaning racks



Example of application: variogrid base plate with  
frame, ensures combination with tech-rack racks



### Dividers

Adapted to respective plate size, enable partitions fitting  
the size of the workpieces  
Available in heights of 28, 42, 69 and 96 mm

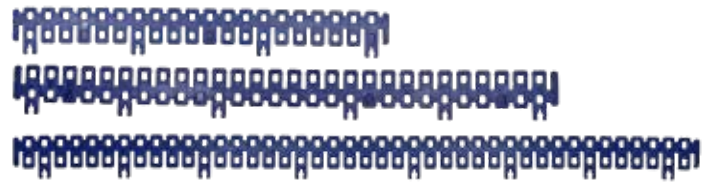

Lengths: 272 mm / 376 mm / 558 mm



Lengths: 272 mm / 376 mm / 558 mm

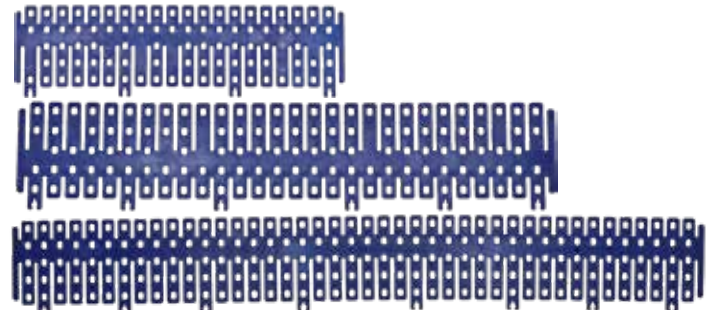

Lengths: 272 mm / 376 mm / 558 mm

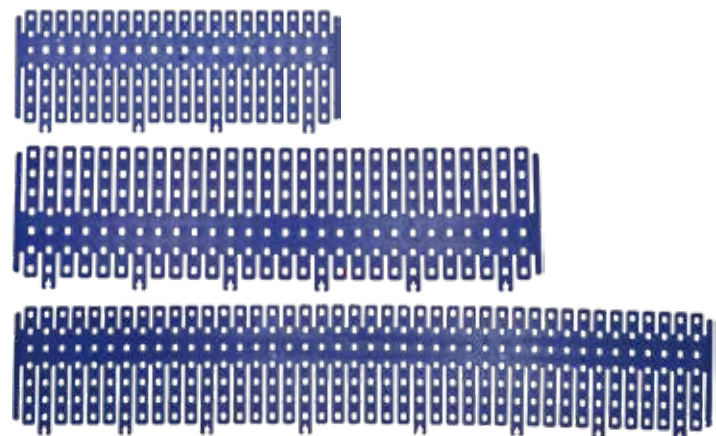

Lengths: 272 mm / 376 mm / 558 mm



**ESD – electrically conductive workpiece carriers**

## The system components: Material Comp 25 (ESD)

The material type Comp 25 offers protection of sensitive electronic components against electrostatic discharge. Generation of electrostatic charges is prevented and already existing charges are safely discharged.

### tech-rack variogrid workpiece carrier plate

Basic dimensions 600 x 400 mm, height 13 mm  
The plate can be cut to individual sizes.  
(see page 24)



### Top frame low

600 x 400 mm, height 36 mm,  
combinable with tech-rack variogrid  
and tech-rack cleaning racks



### Top frame high

600 x 400 mm, height 63 mm,  
combinable with tech-rack variogrid  
and tech-rack cleaning racks



### Dividers

Adapted to respective plate size, enable partitions fitting the size of the workpieces  
Available in heights of 28, 42, 69 and 96 mm

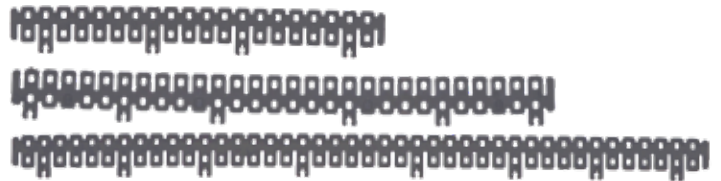

Lengths: 272 mm / 376 mm / 558 mm

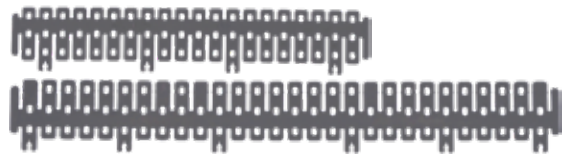

Lengths: 272 mm / 376 mm / 558 mm

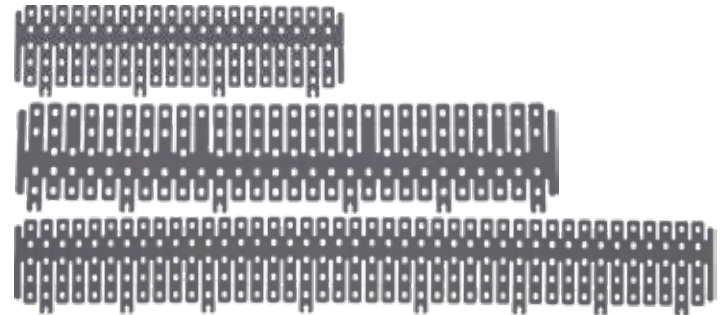

Lengths: 272 mm / 376 mm / 558 mm

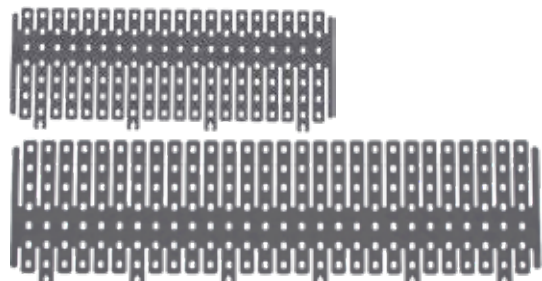

Lengths: 272 mm / 376 mm / 558 mm

## The system components: Accessories

### Rotating stacking bolts

The rotating stacking bolts can be positioned on the base plate in any way to allow for stackability at any size.

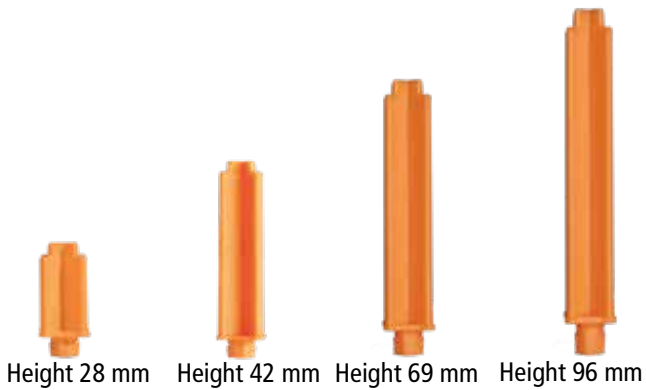

### ESD rotating stacking bolts

The ESD rotating stacking bolts can be positioned on the base plate in any way to allow for stackability at any size.



### Handles

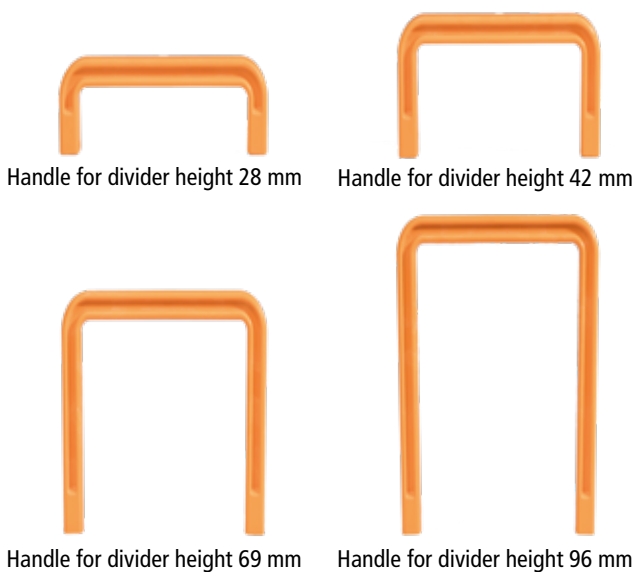

### Press-fit bases

The press-fit bases can be driven into the tech-rack variogrid base plate. This enables a large number of fastening options, such as hooks, bolts, handles and many more.

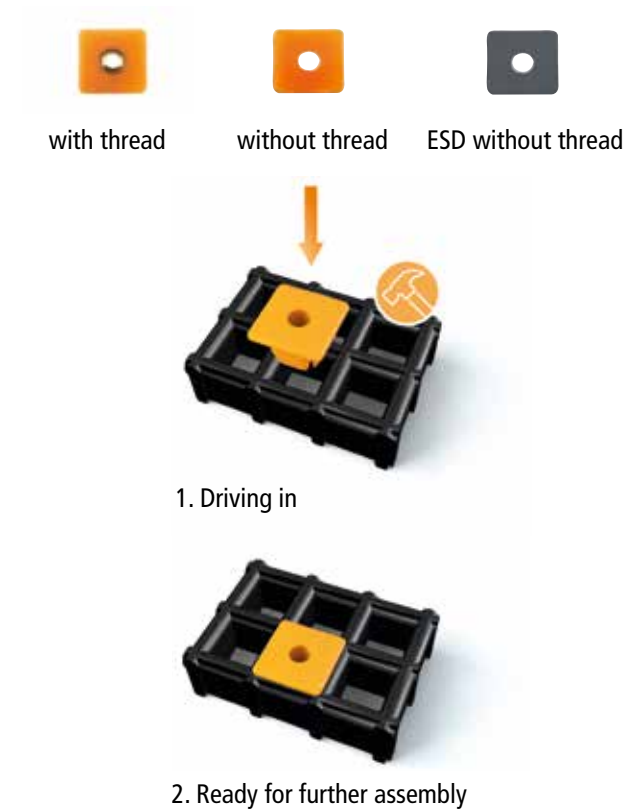

### ESD handles



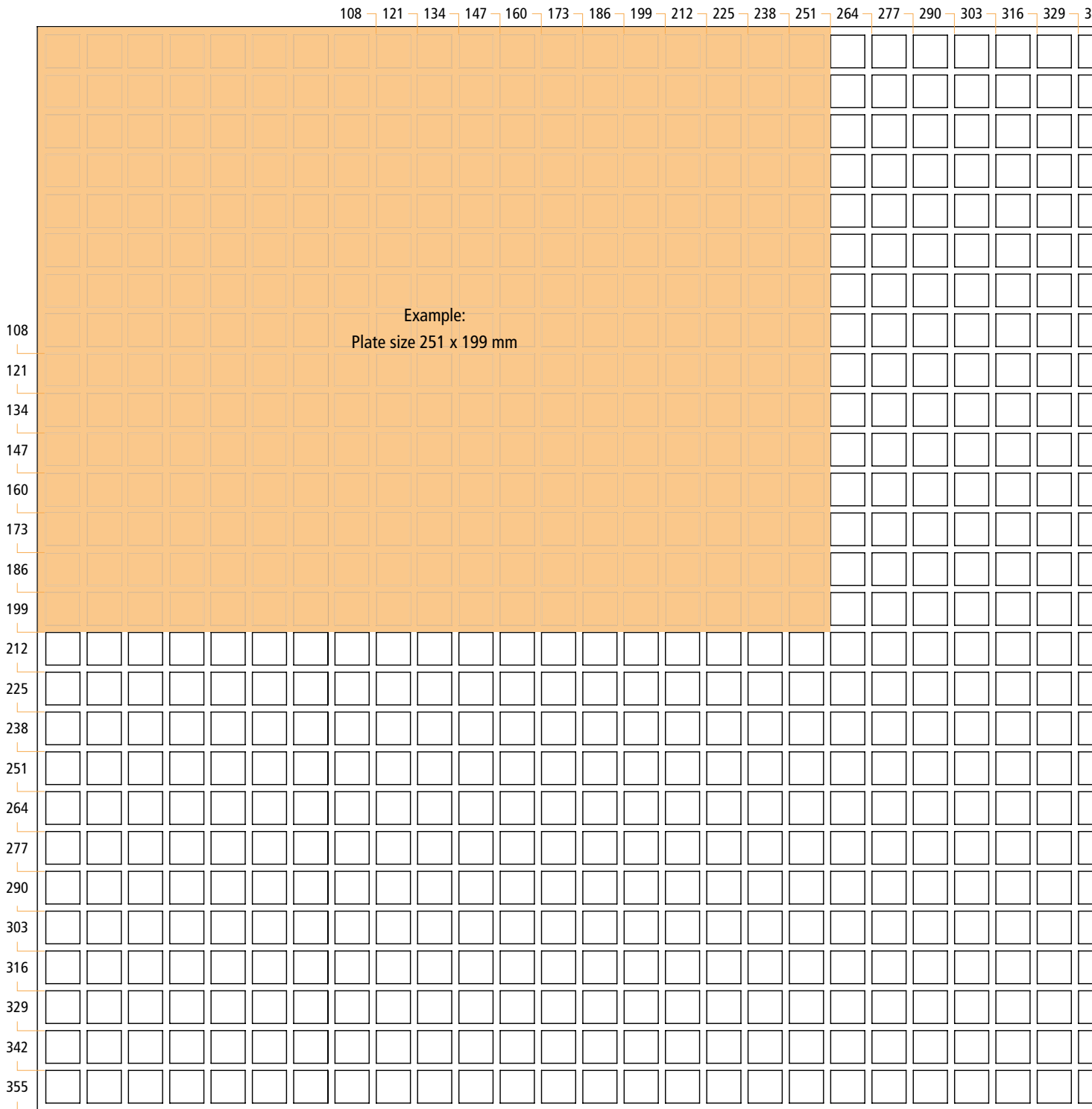

Dimensions in mm, tolerance +/- 1.5 mm



## TECHTRAY WORKPIECE CARRIER 425 X 276

---

**THE VERSATILE ONE** in standard rack/compartment rack or  
as separate workpiece carrier

---

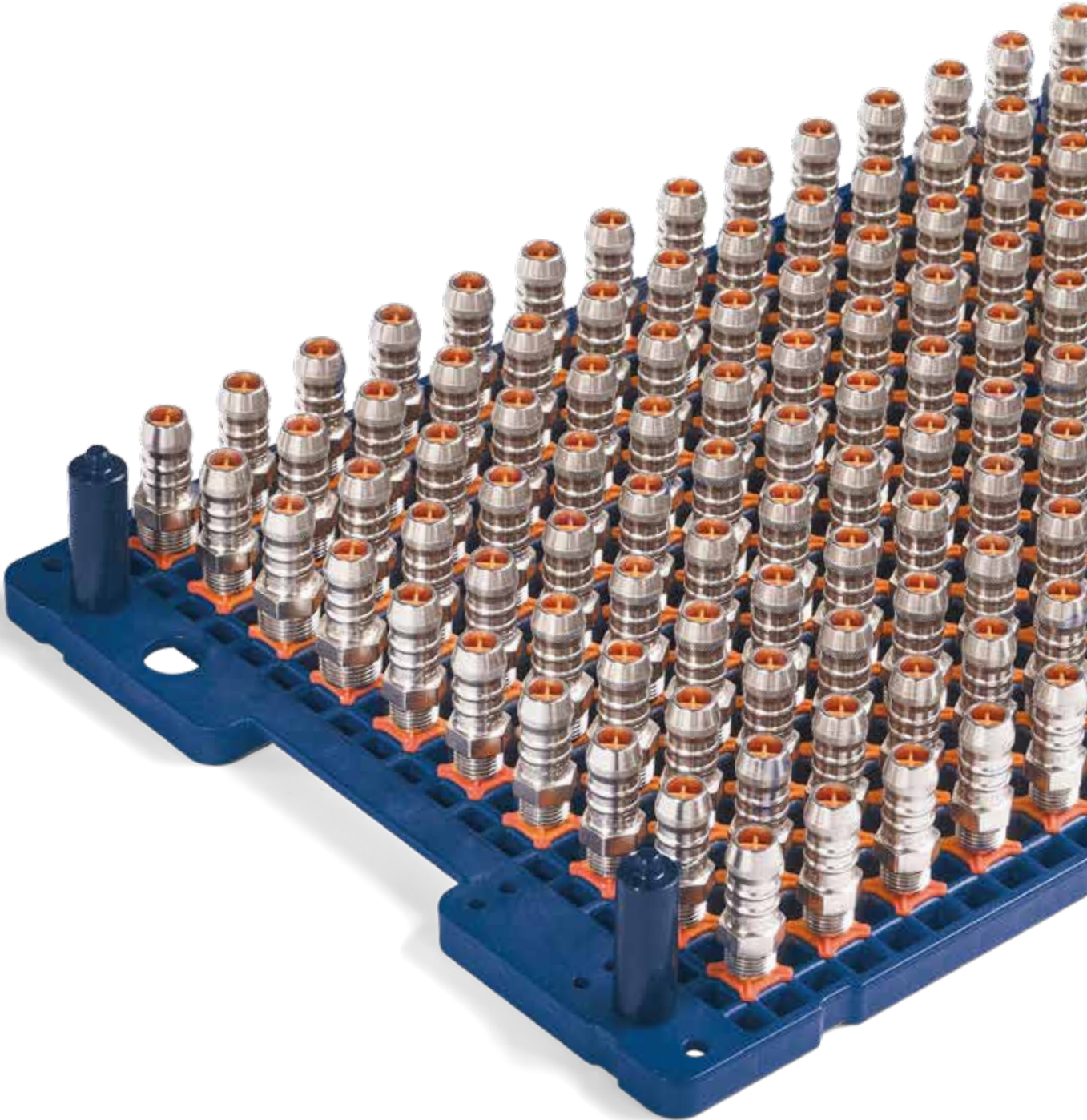

# techtray workpiece carrier

»techtray - absolute component protection and flexibility.

The convincing workpiece carriers from FRIES for logistics, cleaning and storage.«

techtray is a modular workpiece carrier for increased safety and efficiency in industrial component cleaning and internal production logistics. To achieve optimum cleaning in highly sensitive areas like metal processing, optics, medical technology, mechatronics, microelectronics or precision engineering, techtray combines the advantages of plastic workpiece carriers with the design of a metal mesh rack base.

Securing of workpieces in a specific position and at dedicated points ensures protection against damage and optimum flushing during cleaning. This makes techtray the standard in industrial component cleaning, component handling and component logistics.

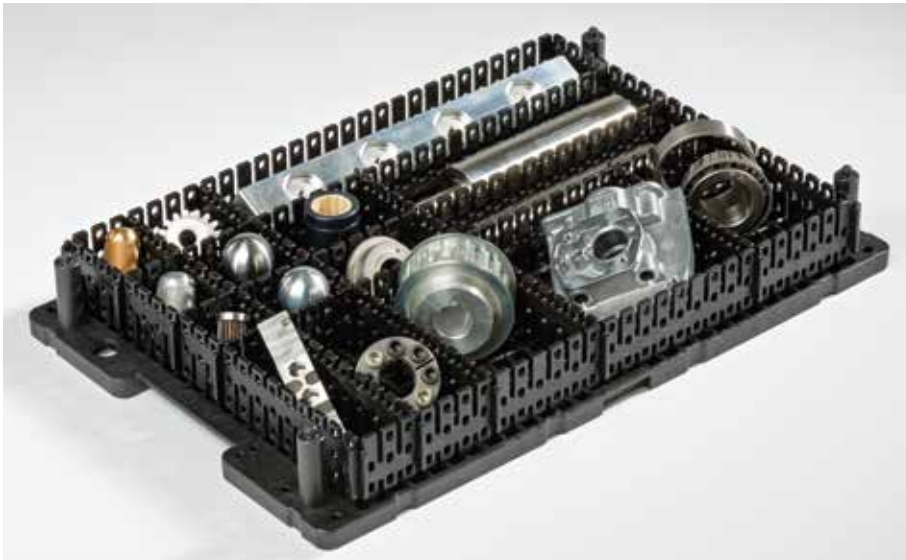

Materials depending on requirements: (see page 5)



Comp 13/14



Comp 21/22



Comp 25



## Base plate in Schäfer 2 format

The techtray plate is adapted for common Schäfer-2 fittings in cleaning systems and transport boxes. This way, techtray can be used in standard racks, compartment racks or as separate workpiece carrier.



## Precise positioning for optimum protection of components

Rotating and plug pins can be flexibly mounted on the techtray plate connection system without any tools. Components are exactly and precisely positioned and protected against dents and scratches.



## Flexible and easy adjustment of partitions with dividers

By means of dividers, a 9 mm grid can be set. They are available in four heights. The bottom and partitions feature sufficient openings for even and thorough rinsing & drying.

## Examples of use



Example of use: techtray stacked 2 times



Example of use: techtray stacked 3 times with lid



Example of use: techtray stacked 2 times in compartment rack with closure lid



Example of use: techtray stacked 3 times in compartment rack with retainer frame

### Further advantages

- » Suitable for full automation and robotic handling
- » Recessed grips at the plate for more efficient use of space
- » Multi-tray function (bottom=lid)
- » Stackable by means of stacking bolts and therefore variable height
- » Combinable with tech-rack variogrid
- » Dividers plugged into the bottom counter the capillary effect
- » ESD-compatibility (entering ESD protection zones with the same workpiece carrier for assembly)
- » Smooth edges enable optimum flow behaviour and reduce the risk of injury

## Numerous rotating and plug pins

Many rotating and plug pins for shafts, sleeves, turned parts, milled parts and many more are available to precisely position the components on the techtray plate. Special designs on request.



## Vaiable in height and stackable

By means of stacking bolts, several techtray plates can be stacked. Four different standard heights are available. On request, stacking heights precise to the millimetre can be provided.



## Variety of fastening options

The press-fit bases ensure a large variety of fastening options. In this way, threads, screws, hooks or handles can be mounted on the base plate easily.



## References

### COMVAT AG Haag (CH)

The techtray workpiece carrier system is used for the entire process from the turning lathe to storage and during assembly. In this way, the workpiece carriers are equipped at the turning lathe and then cleaned in fully-automatic ultrasound cleaning with 7 baths. The cleaning is performed in the clean room ISO8 environment. While doing so, the absence of films and visual cleanliness (vacuum compatibility) is in the centre of attention. Afterwards, the workpiece carriers are stacked in Euroboxes for storage and further assembly.



### SCHNEEBERGER AG Roggwil (CH)

At the specialist in linear technology, the techtray workpiece carriers are used from the lathe over cleaning down to final packaging. Besides a high degree in cleanliness, optimum protection of workpieces in processing over the entire plant is ensured. This way, the costs for intermediate packaging are saved. The marking ensures that the workpiece carrier is available at the workplace with the right compartments.





**Comvat AG, Haag (CH)**

**Herbert Hager**



"We focus on efficiency and cleanliness in the entire production process. To achieve this aim, we use the techtray system as basis."



**Schneeberger AG, Roggwil (CH)**

**Marc Meier**



"The workpiece carriers from FRIES are light-weight, flexible and secure in the process. This enables savings in time and costs at high degrees of cleanliness."

## The system components: Material Comp 13/14

The material type Comp 13/14 was designed for basic requirements in industrial component cleaning and is suitable for cleaning processes with aqueous and solvent-based media and ultrasound applications.

### techtray workpiece carrier plate

425 x 276 mm

The workpiece carrier plate can be used both as bottom and as lid.

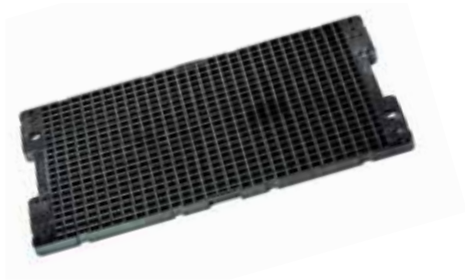

### Dividers

Adapted to respective plate size, enable partitions fitting the size of the workpiece

Available in heights of 28, 42, 69 and 96 mm



Lengths: 272 mm / 376 mm

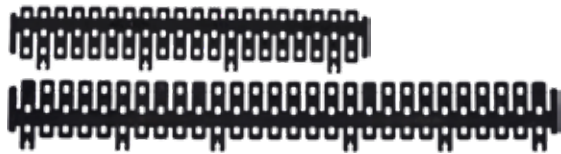

Lengths: 272 mm / 376 mm

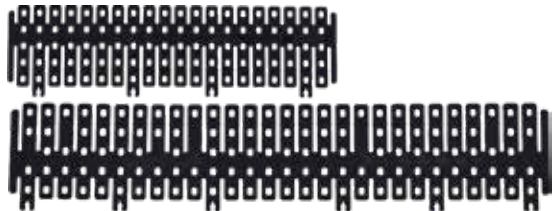

Lengths: 272 mm / 376 mm

### Stacking bolts for techtray

The stacking bolt enables stacking of workpiece carrier plates at variable height.



Height  
28 mm

Height  
42 mm

Height  
69 mm

Height  
96 mm

Special heights are available on request!

Example of use: techtray workpiece carrier plate can be stacked in a compartment rack.

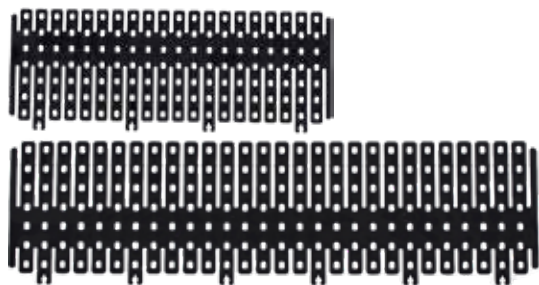

Lengths: 272 mm / 376 mm

## The system components: Material Comp 21/22

The material type Comp 21/22 offers the advantage of even higher chemical and thermal resistance and meets higher requirements in industrial component cleaning.

### techtray workpiece carrier plate

425 x 276 mm

The workpiece carrier plate can be used both as bottom and as lid.



### Stacking bolts for techtray

The stacking bolt enables stacking of workpiece carrier plates at variable height.

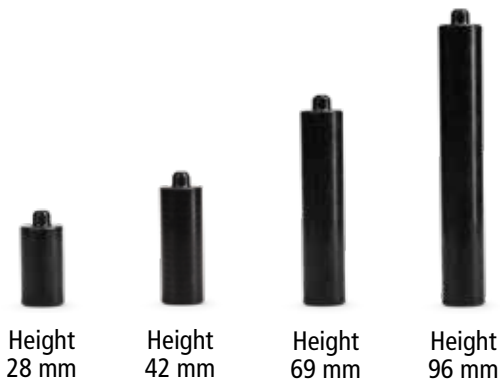

Special heights are available on request!

### Dividers

Adapted to respective plate size, enable partitions fitting the size of the workpiece

Available in heights of 28, 42, 69 and 96 mm



Lengths: 272 mm / 376 mm



Lengths: 272 mm / 376 mm

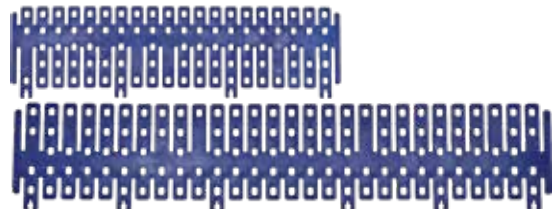

Lengths: 272 mm / 376 mm

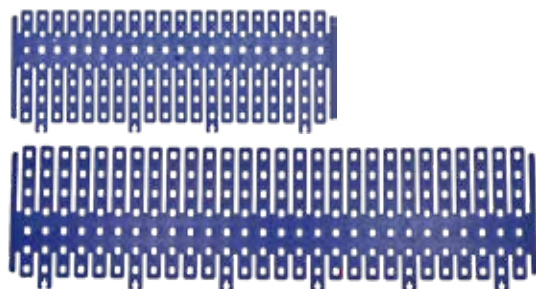

Lengths: 272 mm / 376 mm



**ESD - electrically  
conductive  
workpiece carriers**

## The system components: Material Comp 25 (ESD)

The material type Comp 25 offers protection of sensitive electronic components against electrostatic discharge. Generation of electrostatic charges is prevented and already existing charges are safely discharged.

### techtray workpiece carrier plate

425 x 276 mm

The workpiece carrier plate can be used both as a base and as a cover.



### Dividers

Adapted to respective plate size, enable partitions fitting the size of the workpiece

Available in heights of 28, 42, 69 and 96 mm



Lengths: 272 mm / 376 mm

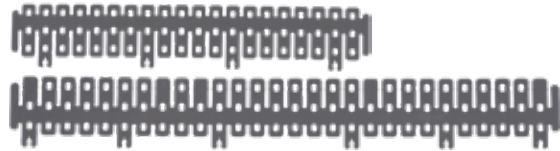

Lengths: 272 mm / 376 mm

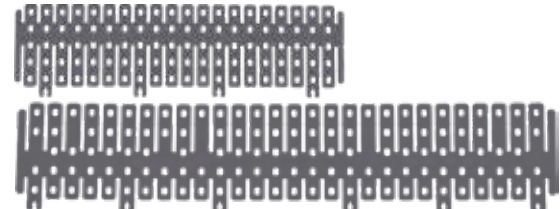

Lengths: 272 mm / 376 mm

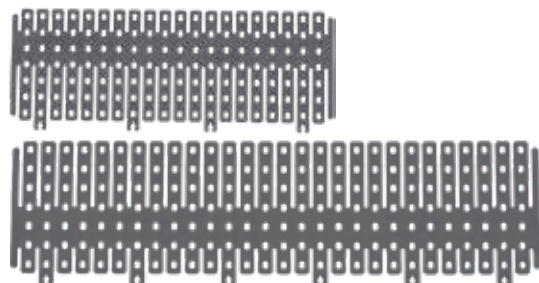

Lengths: 272 mm / 376 mm

## The system components: Accessories

### Rotating stacking bolts

The rotating stacking bolts can be positioned on the base plate in any way to allow for stackability at any size.

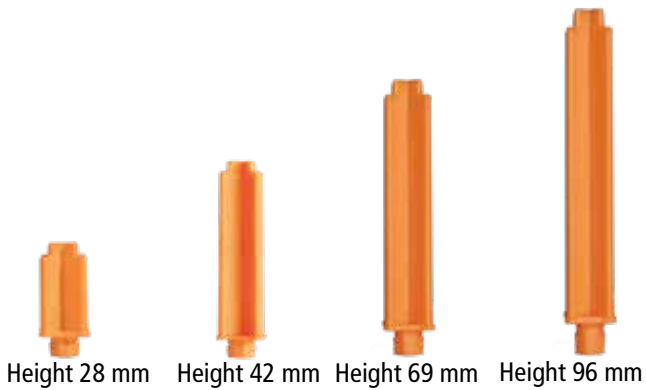

### ESD rotating stacking bolts

The ESD rotating stacking bolts can be positioned on the base plate in any way to allow for stackability at any size.



### Handles

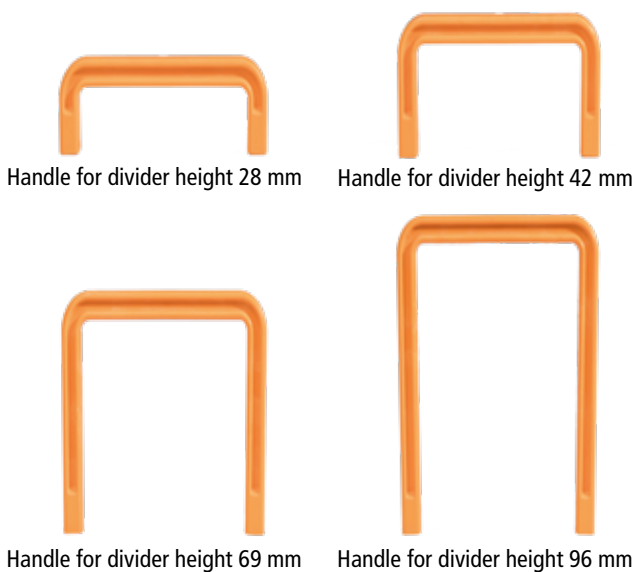

### Press-fit bases

The press-fit bases can be driven into the techtray base plate. This enables a large number of fastening options, such as hooks, bolts, handles and many more.

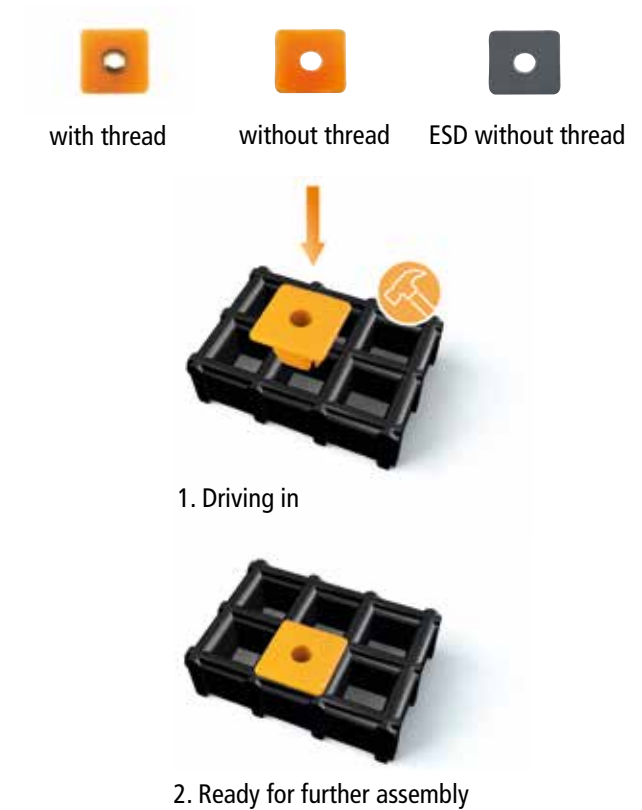

### ESD handles



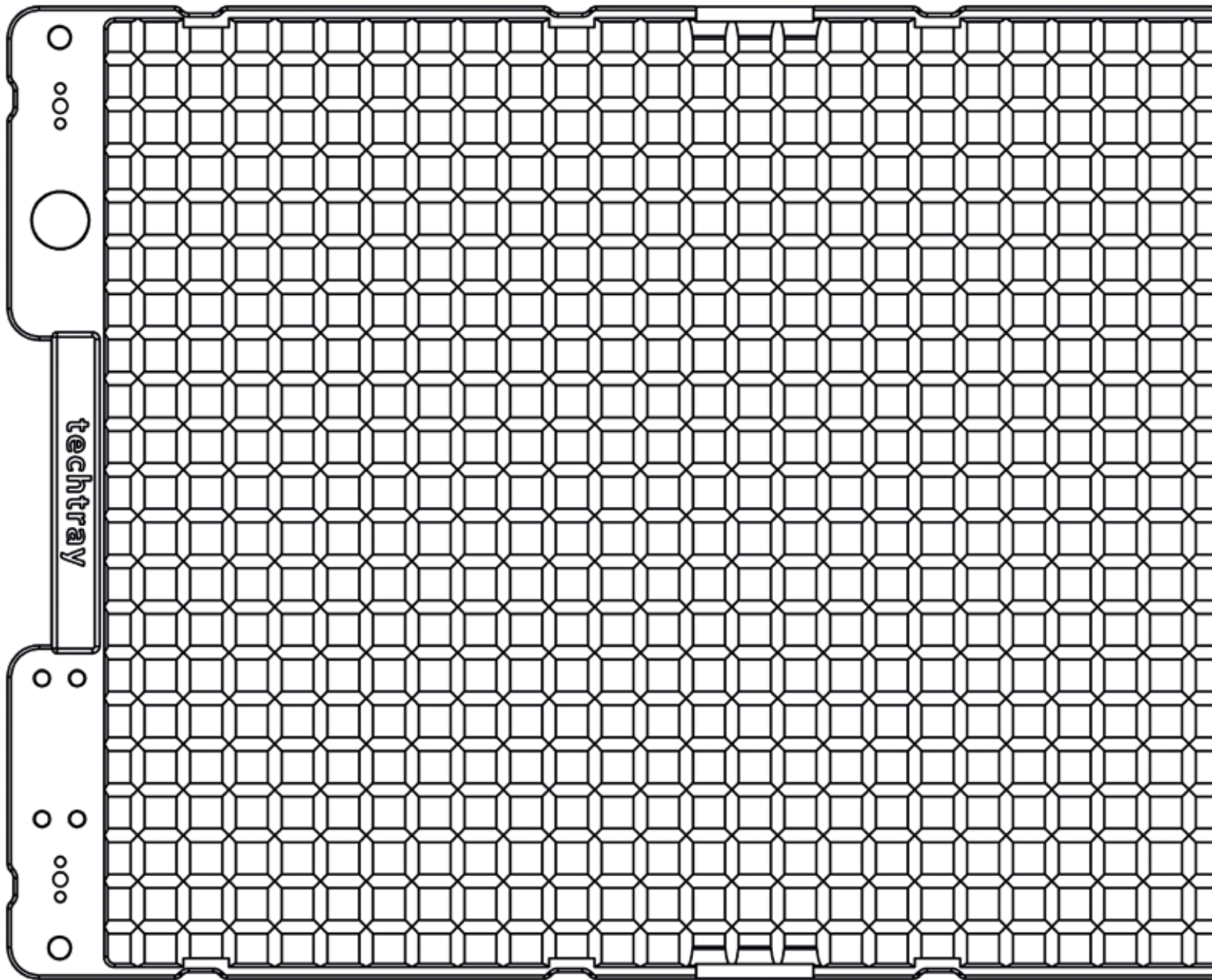

### Flexible division

Thanks to universal partitions and plug-in options, the techtray can be divided optimally according to the respective requirements.

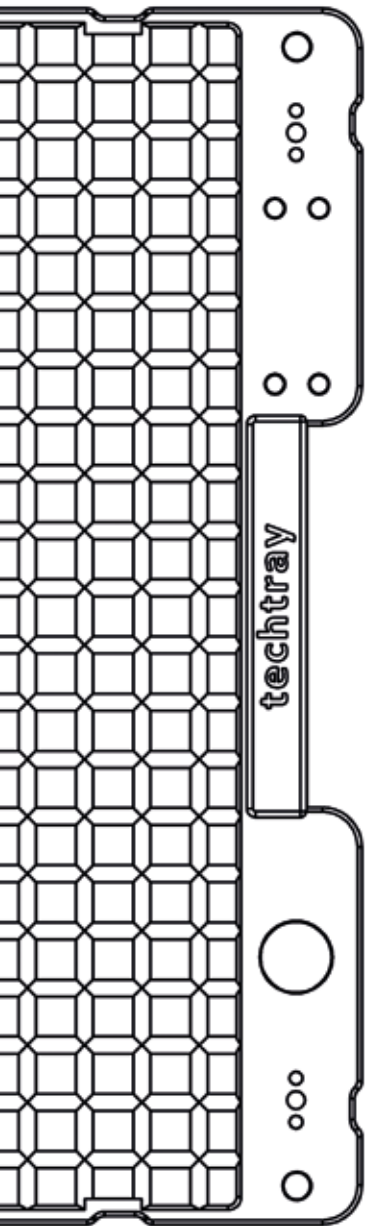

## TECH-RACK CUSTOM<sup>+</sup> CLEANING RACK 400 X 300

**THE VARIABLE ONE** designed especially for use in automated production workflows

**NEW**



# tech-rack custom<sup>+</sup> cleaning rack

"tech-rack custom<sup>+</sup> – ideal for automated production in industry.  
The powerful cleaning rack from FRIES for logistics, cleaning and storage."

The tech-rack custom<sup>+</sup> cleaning rack was developed especially for the new requirements of fully automated production. It allows the thorough and gentle cleaning of high-quality metal parts or sensitive workpieces. Angled stacking edges and studs prevent the capillary effect. The racks are equipped with patented designs that not only allow parts to be loaded and unloaded by robots but also multiple racks to be stacked on pallets with a single gripper arm. The tech-rack custom<sup>+</sup> can be used throughout the entire in-house logistics chain – from cleaning and transport through to storage.



Comp 21/22 material  
(see page 5)



Component-specific gridded base available

The base grid can be custom-built for larger order volumes. Components can then be positioned without pins or dividers.



Complete automation: Loading and unloading by robot

The patented design with a small recess allows fully automated robot handling. See page 14.



Customised expansion with Rotary extender

To ensure stackability at any height, rotary extenders can be positioned at different heights in the corners.

## Easy assembly thanks to rotary extender

Example of assembly with 96 mm rotary extender, frame and cover

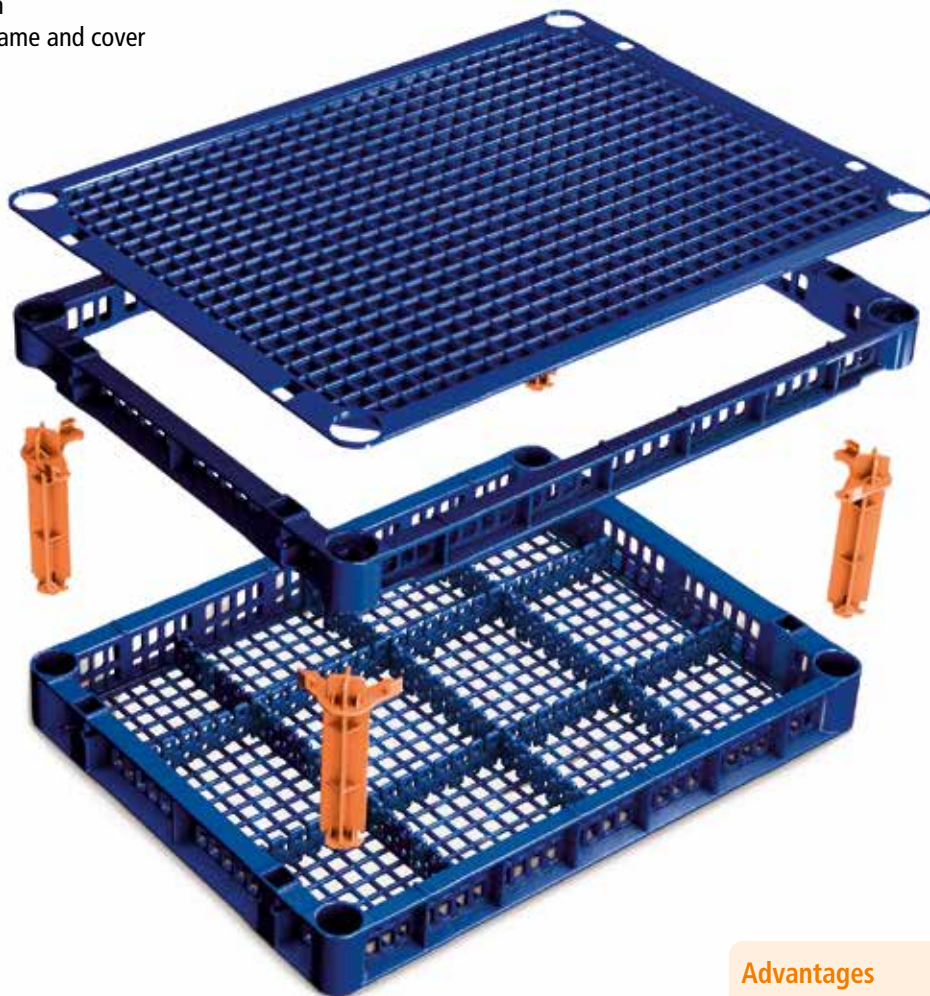

## Optimised component protection

Rotating and plug-in pins, as well as dividers, can be placed in the standard grid base for the precise positioning of components.



## Precise positioning of stamped parts

In addition to turned and milled parts, stamped parts (e.g., with the comb insert) can also be positioned perfectly. Inserts can be custom-made for the component on request.



## Advantages

- » Designed for complete automation
- » Component-related grid base available (components can be positioned without any pins or dividers)
- » Automated loading, unloading and stacking thanks to gripper arms
- » The capillary effect is countered by an angled stacking edge and built-in dividers in the base.
- » Optionally available with recessed grips
- » High load capacity
- » RFID chip available on request
- » Rounded corners offer protection against damage

# tech-rack custom<sup>+</sup> cleaning rack

"Versatile all-rounder for customised use"

The tech-rack custom<sup>+</sup> industrial rack ensures maximum product protection as well as safeguarding from damage and harm to sensitive surfaces during every step throughout the production process

Use of pins and dividers to provide optimum component protection



Rotating and plug-in pins, as well as dividers, can be placed in the standard grid base for the precise positioning of components.

Angled stacking edge prevents the capillary effect

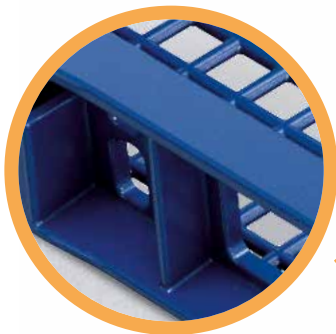

The angled stacking edges with stacking studs prevent liquids from migrating to the components and damaging them due to the capillary effect.

Rack heights can be extended as needed via rotary extenders



To ensure stackability at any height, rotary extenders can be positioned at different heights in the corners.

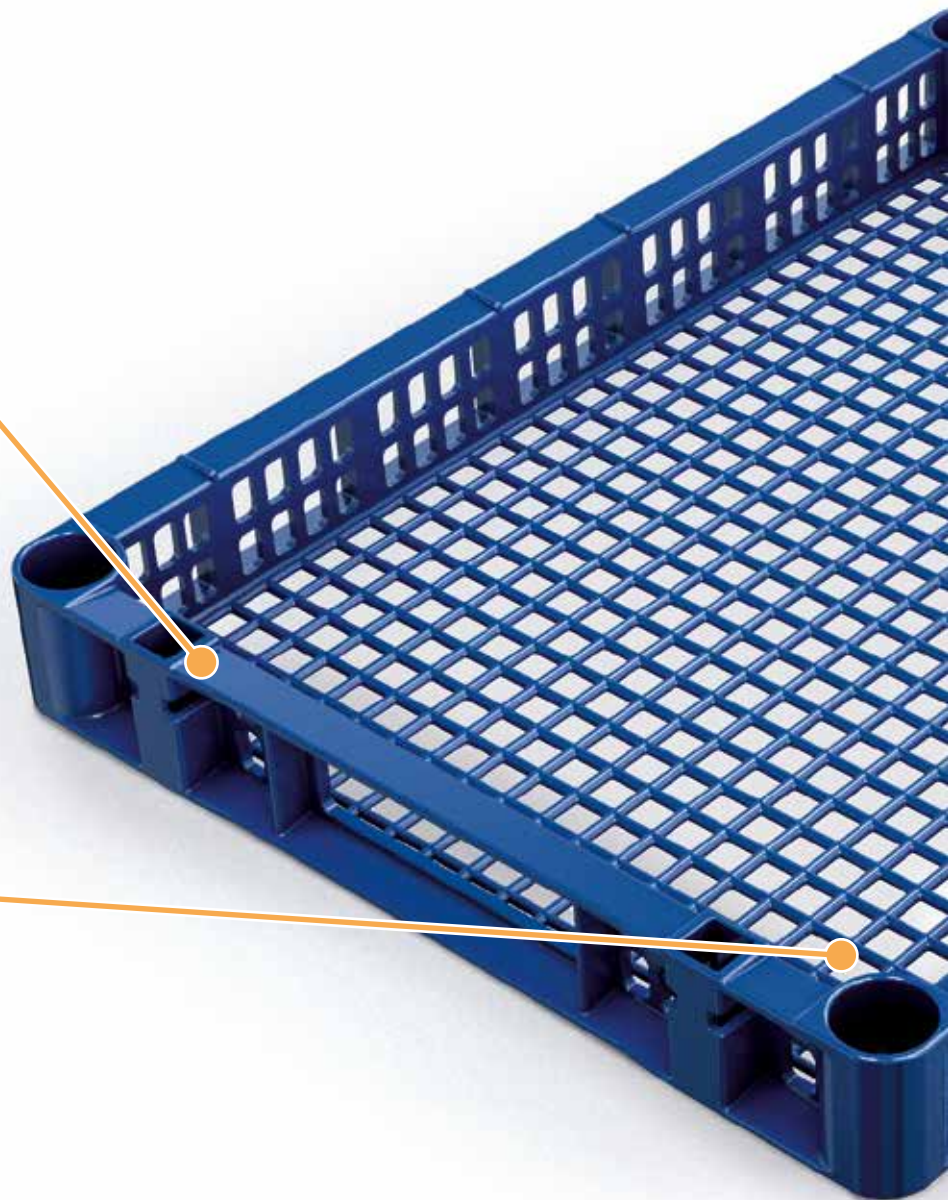

**Complete automation: Loading and unloading by robot**



The patented design with a small recess allows fully automated robot handling.

**Optionally with recessed grip for easier handling**

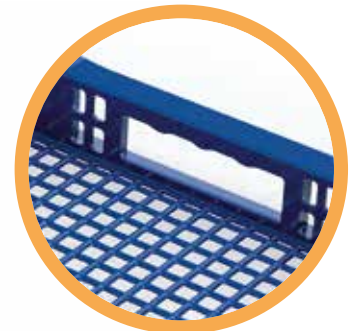

For easier handling, the tech-rack custom\* cleaning rack is also available on request with recessed grips.

**Component-specific grid base**

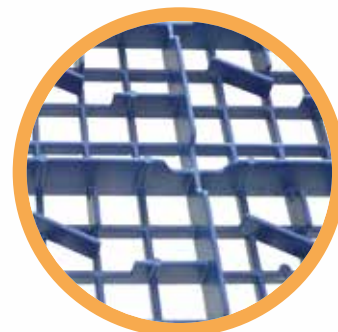

The base grid can be custom-built for larger order volumes. Components can then be positioned without pins or dividers.

## The system components: Comp 21/22 material

The Comp 21/22 material offers even higher chemical and thermal resistance and is therefore suitable for more exacting demands in industrial parts cleaning

### tech-rack custom<sup>+</sup> cleaning rack

400 x 300 mm  
External height 50 mm / clear internal height 30 mm



Standard rack with variogrid gridded base (figure) – the grid base can be custom-built for larger order volumes.

### tech-rack custom<sup>+</sup> frame for base rack

400 x 300 mm, height 30 mm  
Can be combined with the tech-rack custom<sup>+</sup>

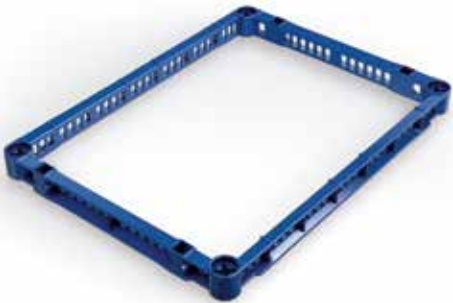

### tech-rack custom<sup>+</sup> cover for base rack

400 x 300 mm, height 13 mm  
Can be combined with the tech-rack custom<sup>+</sup>



### Dividers

Adapted to respective plate size, enable partitions fitting the size of the workpieces  
Available in heights of 28, 42, 69 and 96 mm



Lengths: 257 mm / 361 mm



Lengths: 257 mm / 361 mm

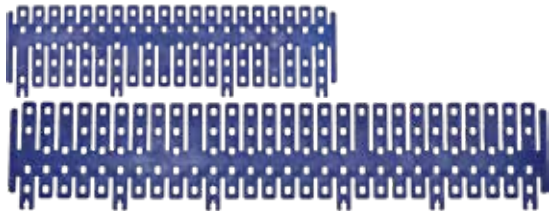

Lengths: 257 mm / 361 mm

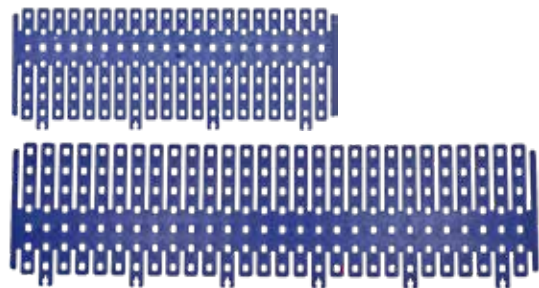

Lengths: 257 mm / 361 mm

### Ridge insert

2,9 x 78 x 361 mm  
for stamped parts



## The system components: Accessories

### Rotary extender

The rotary extenders can be positioned in the corners to ensure stackability at any height.

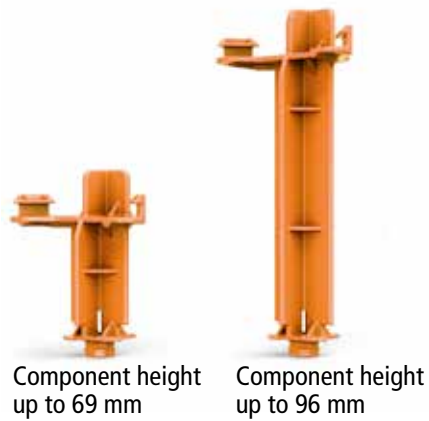

### Easy assembly

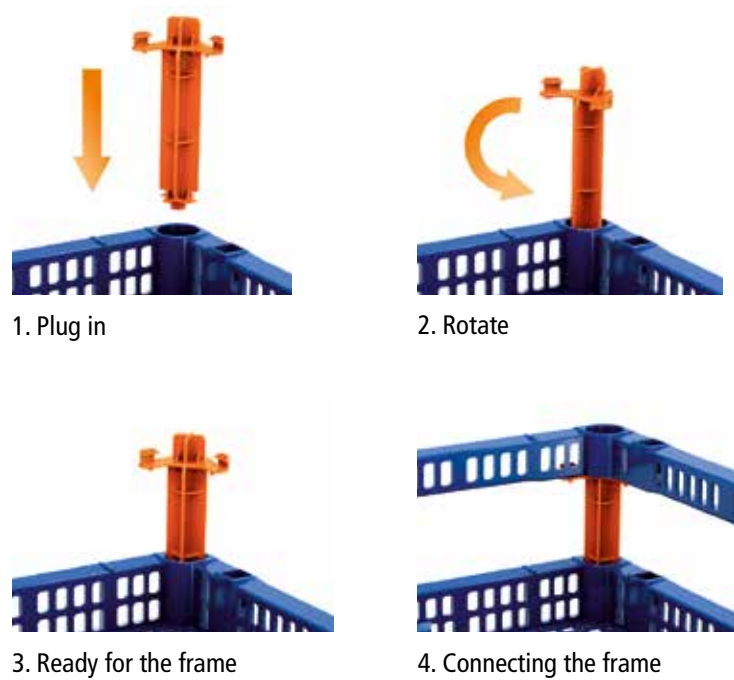

### Press-fit bases

The press-fit bases can be driven into the variogrid base plate. This allows a variety of fastening options for hooks, bolts, handles and much more.



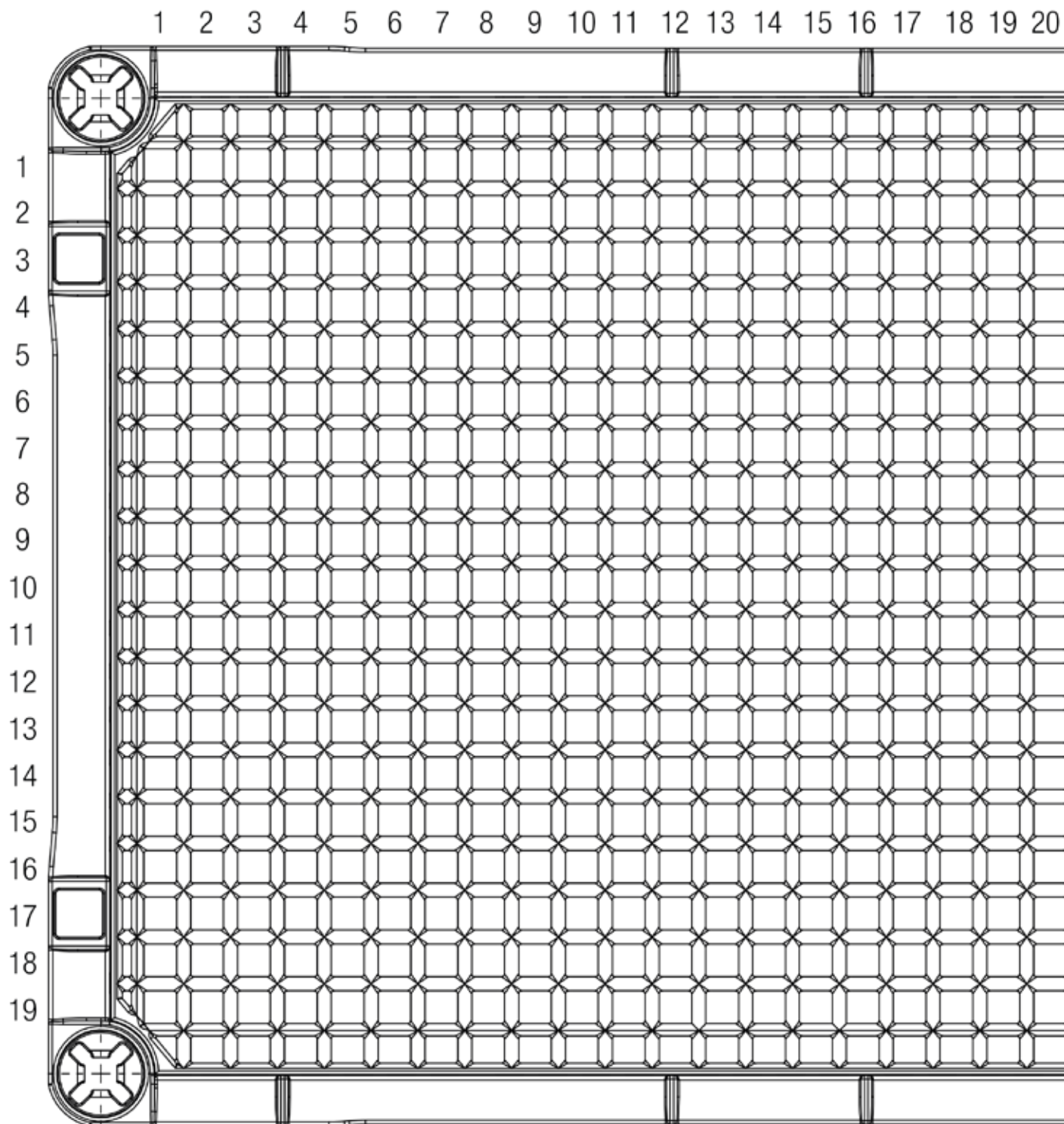

Dimensions in mm, tolerance +/- 1.5 mm

21 22 23 24 25 26 27

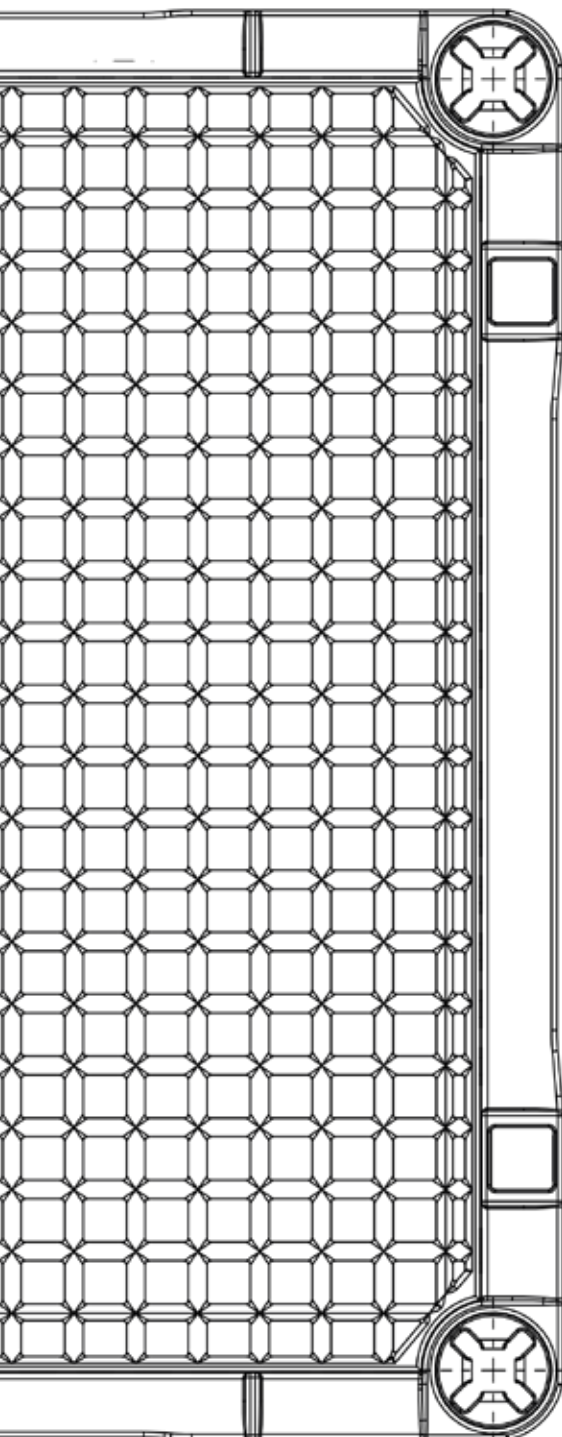

## **TECH-RACK CUSTOM CLEANING RACK 600 X 400**

---

**INDUSTRY 4.0** Developed for automated manufacturing processes

---

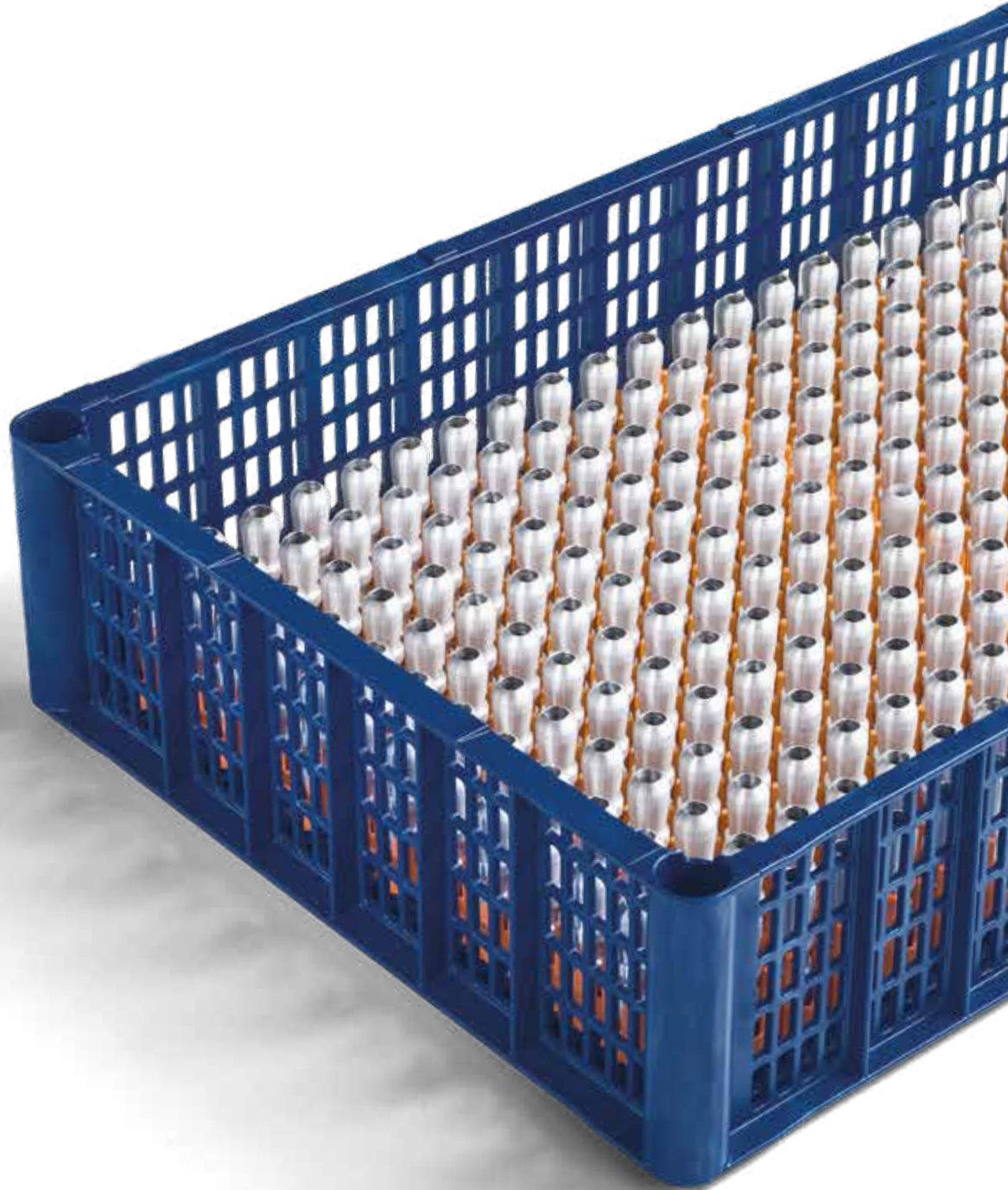

# tech-rack custom 4.0 cleaning rack

»tech-rack custom - the ideal solution for industrial automated manufacturing applications.  
The high-performance workpiece carrier from FRIES for logistics, cleaning and storage.«

The tech-rack custom cleaning rack is designed for the latest industrial requirements in fully automated manufacturing. High-quality metal components or sensitive workpieces are thoroughly and gently cleaned by rinsing and the capillary effect is countered thanks to inclined stacking edges and knobs. Thanks to their patented corner design, racks are designed in such a way that they not only enable loading and unloading of components by means of robots but also stacking of multiple racks on pallets with a gripper. The tech-rack custom can be used over the entire internal logistics chain from cleaning over transport down to storage.

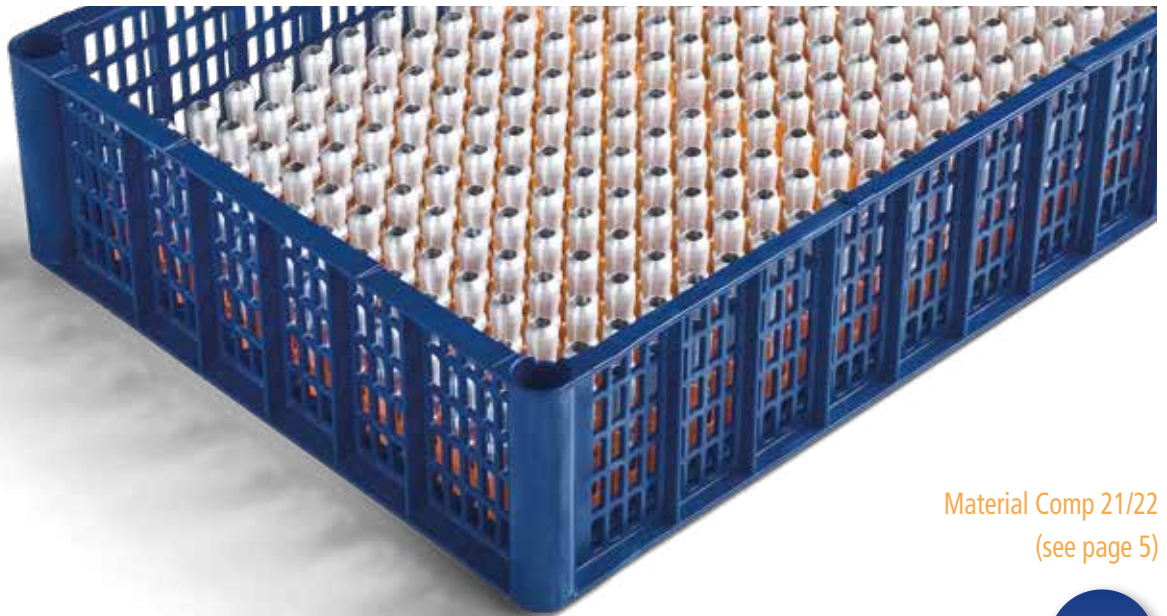

Material Comp 21/22  
(see page 5)



Component-tailored grid bottom available

In larger quantities, the grid bottom can be tailored to customer-specific requirements. This way, pins and dividers are no longer required for component positioning.

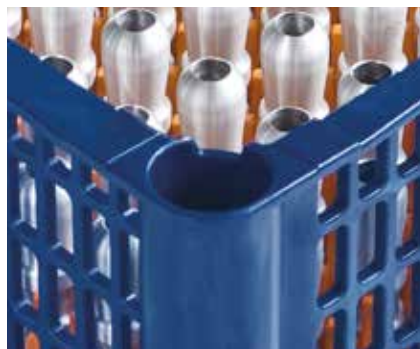

Fully automated: Robotic loading and unloading

The patented corner design with its tiny recess enables fully automated robotic handling.



Inclined stacking edge countering the capillary effect

The inclined stacking edges with stacking knobs prevent fluids from reaching the components due to the capillary effect and causing damage.

## Automation on the rise

In fully automated manufacturing, tech-rack custom cleaning racks can be loaded and unloaded and several racks can be stacked on pallets using a gripper.

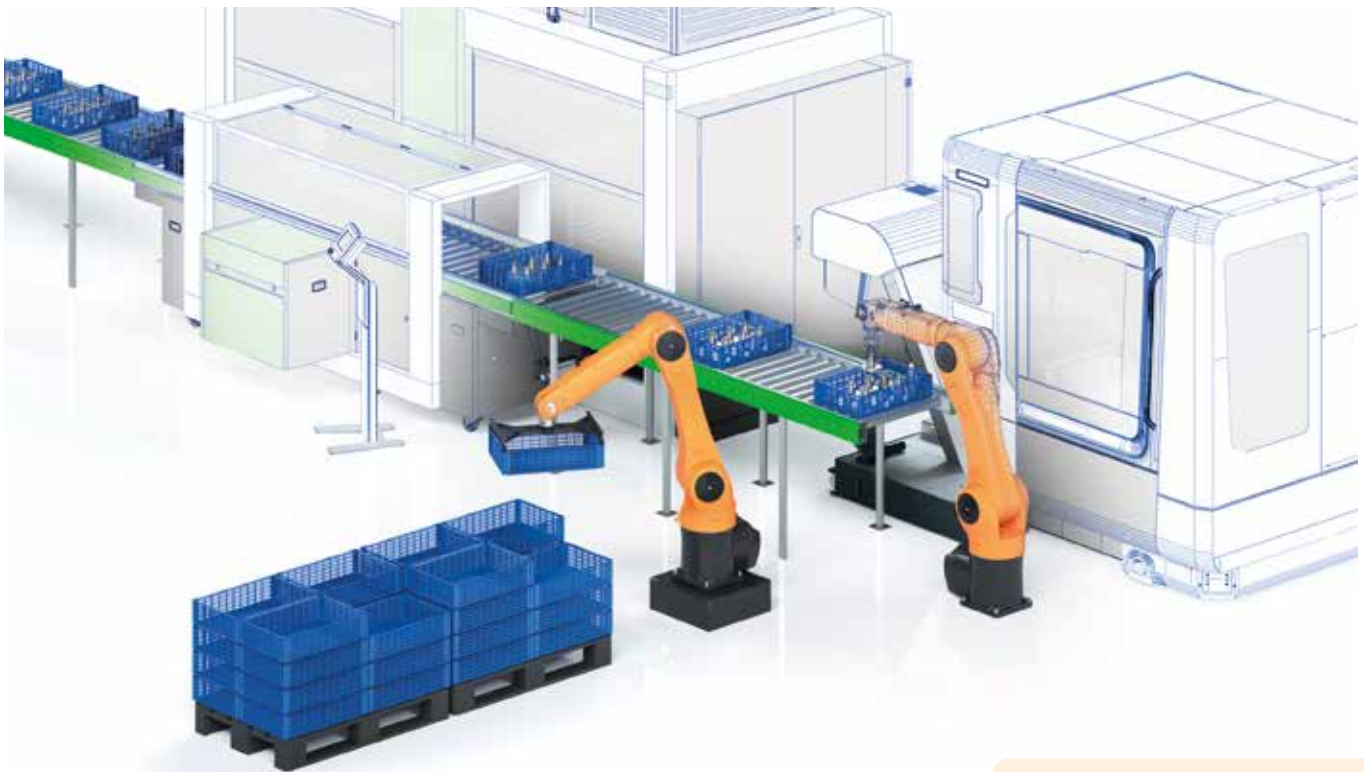

## Optimum protection of components

For exact positioning of components, rotating and plug pins as well as dividers can be attached on the standard grid plate.

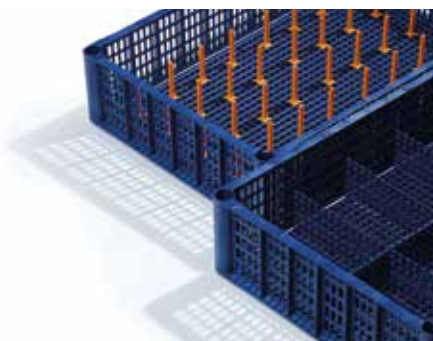

## Efficient cleaning

The tech-rack custom cleaning rack also enables stacking in compartment racks..

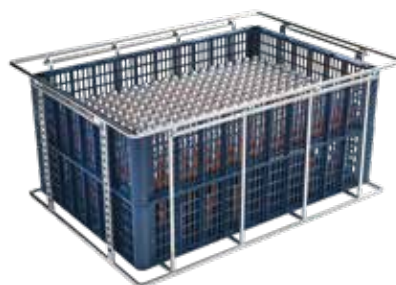

### Further advantages:

- » Smooth corners provide protection from damage and injury at sensitive surfaces
- » Dividers are secured in the bottom plate and counter the capillary effect
- » Rotating pin enabling custom positioning for component fitting
- » Numerous configuration options for fitting of a maximum variety of components
- » Stacking by means of grippers possible
- » RFID chip available on request

# tech-rack custom 4.0 cleaning rack

"All-rounder for individual applications"

The tech-rack custom cleaning rack impresses with its versatility. Thanks to an array of features, it can adapt perfectly to customer-specific requirements and optimised component protection is guaranteed.

**Complete automation:  
Loading and unloading  
by robot**

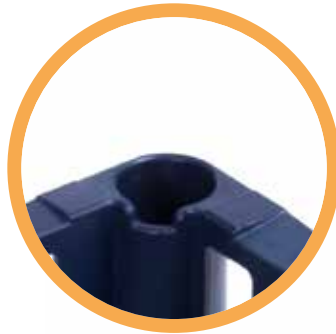

The patented corner design with a small recess allows fully automated robot handling.

**Angled stacking edge  
prevents the capillary  
effect**

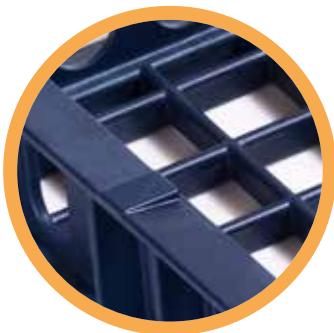

The angled stacking edges with stacking studs prevent liquids from migrating to the components and damaging them due to the capillary effect.





**Component-specific  
grid base**

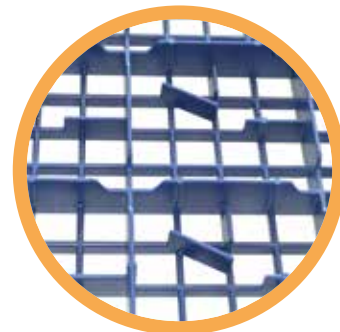

The base grid can be custom-built for larger order volumes. Components can then be positioned without pins or dividers.

## References

### ALUMINIUM PROCESSOR (A)

The tech-rack custom cleaning rack meets the strict requirements of the aluminium-processing company from Austria. The cleaning racks are placed in the automated feed of the cleaning system. There, components are subject to optimised rinsing to ensure clean surfaces without any residues. The tech-rack cleaning rack is used over the entire internal and external logistics chain.





## The system components: Material Comp 21/22

The material type Comp 21/22 offers the advantage of even higher chemical and thermal resistance and meets higher requirements in industrial component cleaning.

### tech-rack custom cleaning rack

600 x 400 mm  
Outer height 138.5 mm / clear inner height 119.5 mm



Standard rack with variogrid bottom (figure) - In larger quantities, the grid bottom can be tailored to customer-specific requirements.

### tech-rack cover for base rack

600 x 400 mm, height 13 mm  
combinable with tech-rack variogrid, tech-rack



### Dividers

Adapted to respective plate size, enable partitions fitting the size of the workpieces  
Available in heights of 28, 42, 69 and 96 mm



Lengths: 257 mm / 361 mm



Lengths: 257 mm / 361 mm

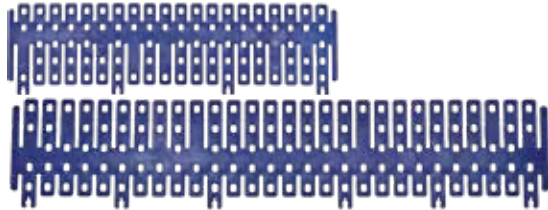

Lengths: 257 mm / 361 mm

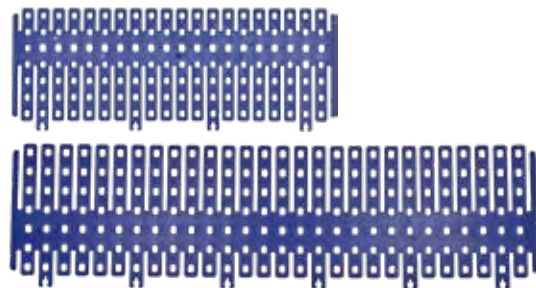

Lengths: 257 mm / 361 mm

### Ridge insert

2,9 x 78 x 361 mm  
for stamped parts



## The system components: Accessories

### Press-fit bases

The press-fit bases can be driven into the variogrid base plate. This enables a large number of fastening options, such as hooks, bolts, handles and many more.



with thread



without thread



1. Driving in



2. Ready for further assembly

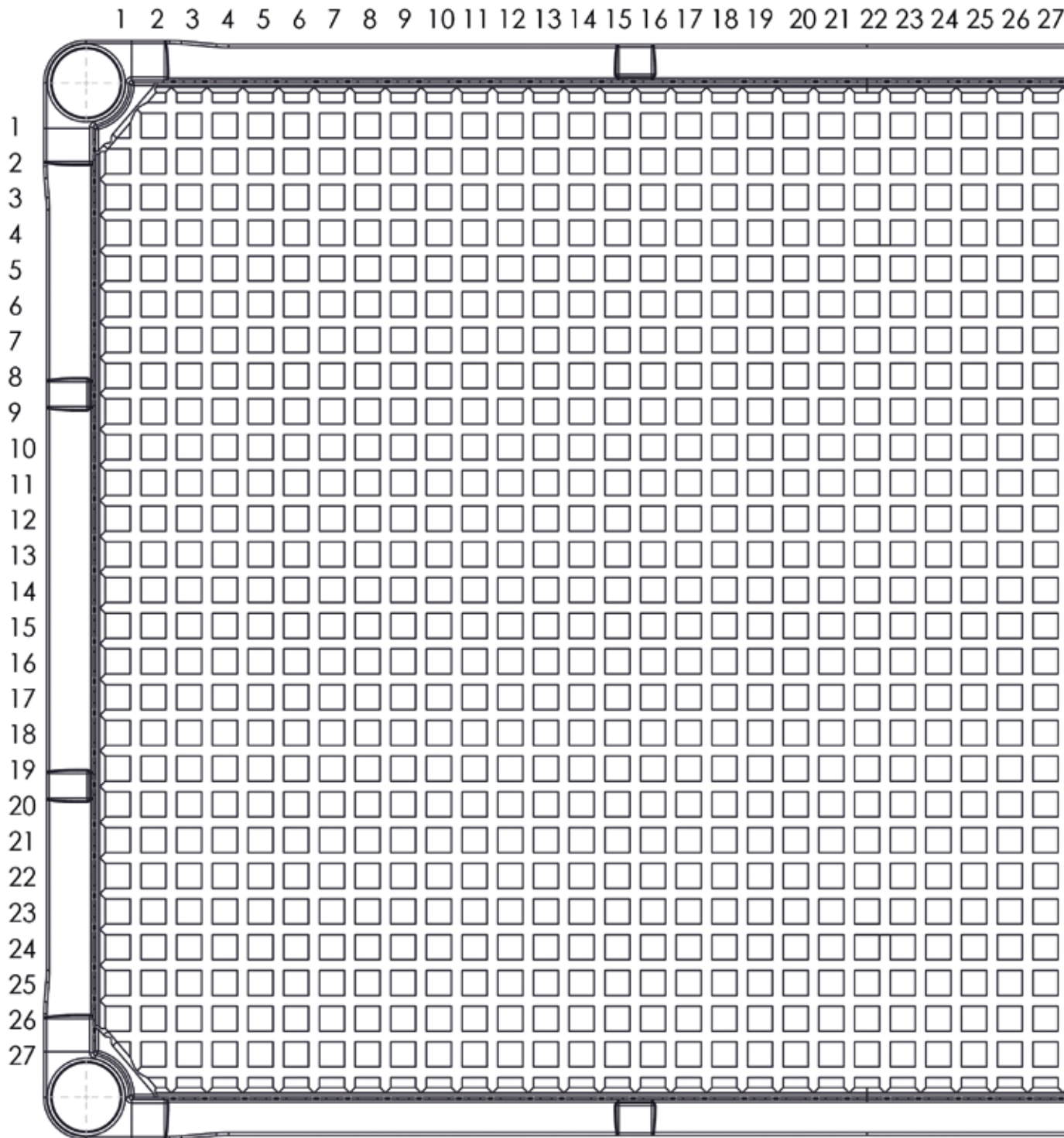

Dimensions in mm, tolerance +/- 1.5 mm

28 29 30 31 32 33 34 35 36 37 38 39 40 41 42 43

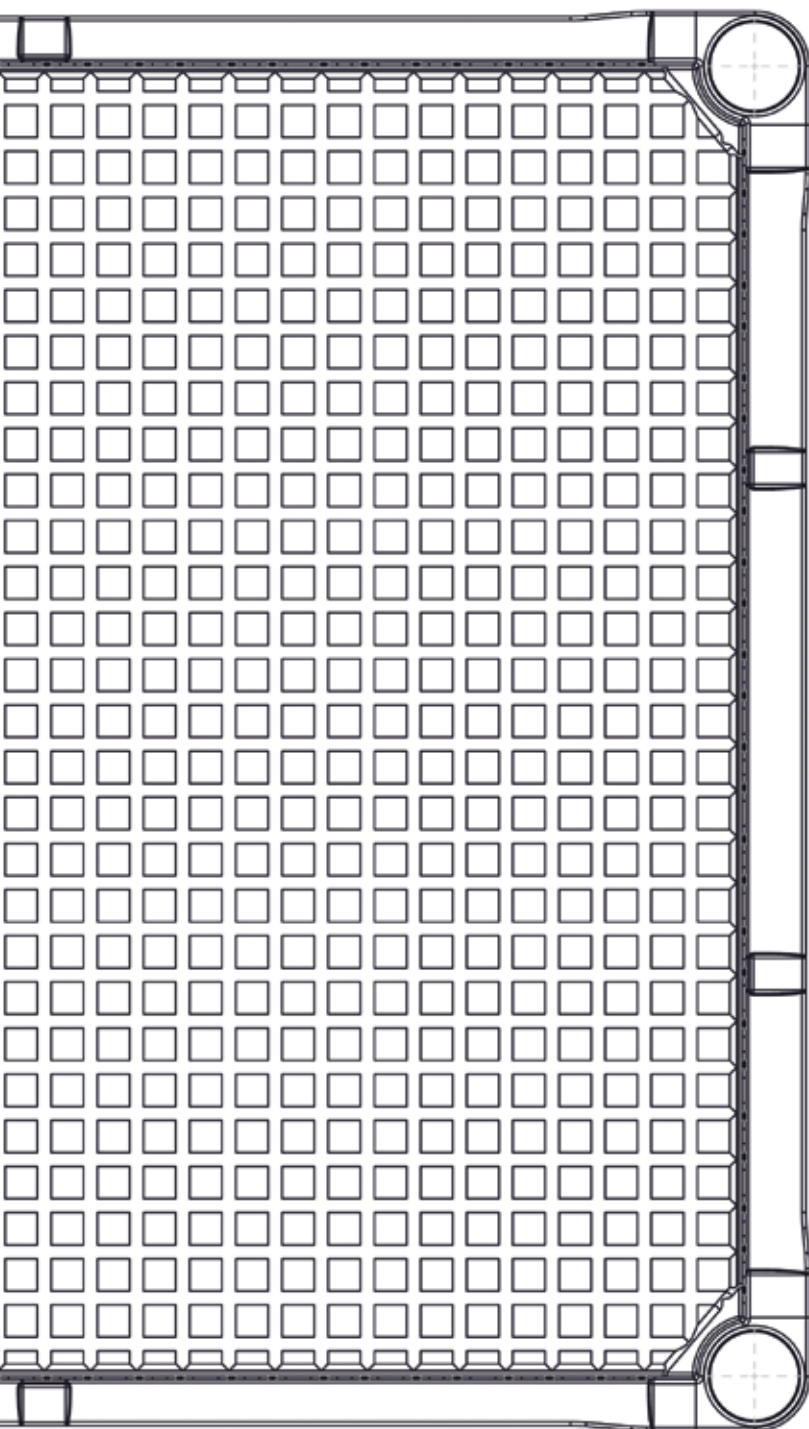

## TECH-RACK CLEANING RACK 600 X 400

---

**THE ADAPTABLE ONE** individual height adjustment,  
convertible for other partition dimensions

---



# tech-rack cleaning rack

»tech-rack 600 x 400 - the efficient all-in-one system for industrial applications.  
The adaptable workpiece carrier from FRIES for logistics, cleaning and storage.«

Workpieces are always of value. For structural components in the field of technology, maximum quality and safety are paramount. This is particularly the case when it comes to complex production processes – from raw parts to precise structural and finished components.

The FRIES tech-rack cleaning rack ensures efficiency and ease of operation at each process stage: Optimum cleaning result, maximum protection for sensitive surfaces, safe transport and perfect storage. To suite different applications, the industrial rack is available in material types Comp 13/14 and Comp 21/22.



Materials depending  
on requirements:  
(see page 5)



Comp 13/14



Comp 21/22



## Modular design

The cleaning rack can be perfectly customised to customer requirements and converted quickly to suite other partition dimensions and heights.



## Efficient cleaning

Optimum cleaning results and maximum cleanliness of components are ensured by the optimised openings at the cleaning rack.

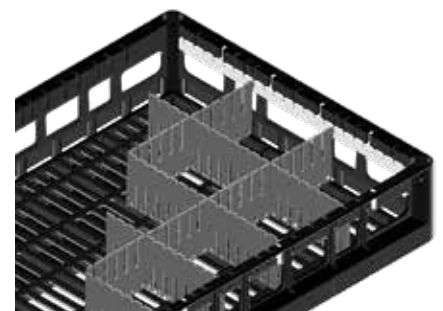

## Flexible and easy adjustment of partitions with dividers

Height adjustment with millimetre precision and a 15 mm grid at the longitudinal and cross sides enable optimum use of space and high levels of protection of components.

## Individual configuration thanks to tube or Clix extender

The tech-rack cleaning rack consists of numerous of individual components and can be adapted to individual component requirements of customer demands – in height as well as in the size of partitions.

The base rack can be loaded with workpieces with a height of up to 72 mm and still remains stackable. With end frames, the rack can be manufactured with a clear inner height as of 135 mm.

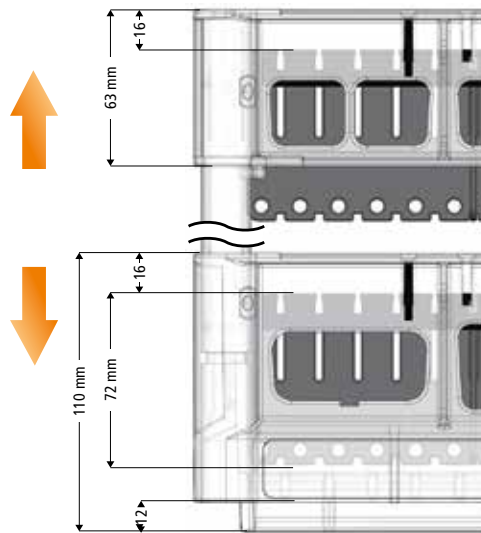

### Custom rack version

For individual heights

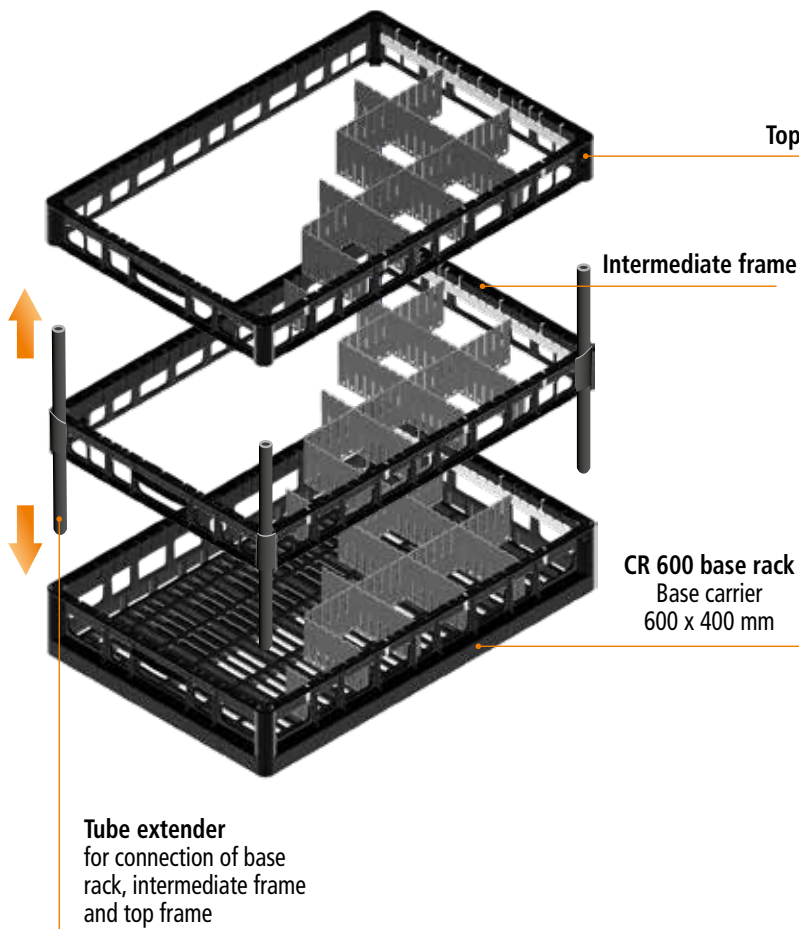

### Clixrack version

For standard heights in steps of 15 mm

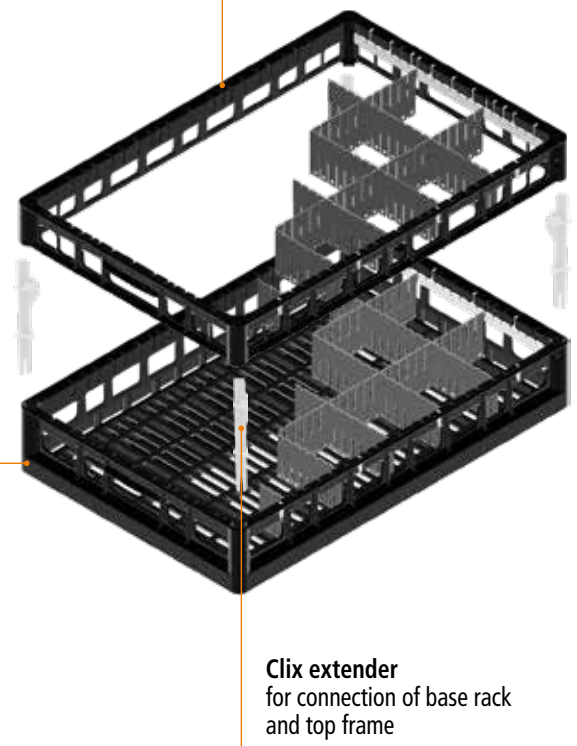

## References

### HAAG-STREIT AG, Koeniz (CH)

The tech-rack cleaning rack is used for larger component geometries. Thanks to its high flexibility, good access for cleaning media and a low weight of the cleaning rack, Haag-Streit enables easy and secure handling of your components.



### BOERS & CO FIJNMETAAL GROUP, Schiedam (NL)

At Boers, more than 2,500 tech-rack cleaning racks are in use. Cleaning is realised with modified alcohols. The racks are used for transport, cleaning and storage





**Haag-Streit AG, Koeniz (CH)**

**Stefan Oetliker**



"We are using a combination of all FRIES systems, tech-rack variogrid, tech-tray and tech-rack depending on the respective component and requirements."



**Boers & Co FijnMetaal Group, Schiedam (NL)**

**Ronald Koot**



"tech-rack enables secure cleaning and transport of our high-quality precision-engineering components made of various materials."

# Variety of configuration options

»Individual, quick and secure assembly without tools«

## Base rack with side rail (open)

Longitudinal and cross dividers in height 70 mm



External rack height: 110 mm (stacked 100 mm)

Extender	Component height up to	Rack outer dimensions	Rack type*
without	72 mm	110 mm	PAA

\* Rack complete without cross and longitudinal dividers

## Base rack with side wall (closed)

Longitudinal and cross dividers in height 34 mm



Longitudinal and cross dividers in height 70 mm



Extender	Component height up to	Rack outer dimensions	Rack type*
without	72 mm	110 mm	PAB

\* Rack complete without cross and longitudinal dividers

## Base rack and top frame with side rail (open)

Longitudinal and cross dividers in height of 70 mm (base rack) and height of 70 mm (top frame)



Extender	Component height up to	Rack outer dimensions	Rack type*
155	155 mm	200 mm	PAC/155
170	170 mm	215 mm	PAC/170
185	185 mm	230 mm	PAC/185
200	200 mm	245 mm	PAC/200
215	215 mm	260 mm	PAC/215
230	230 mm	275 mm	PAC/230
Tube	customised in mm	customised in mm	PARC/...

\* Rack complete without cross and longitudinal dividers

## Base rack and top frame with side panels (closed)

Longitudinal and cross dividers in height of 70 mm (base rack) and height of 70 mm (top frame)



Longitudinal and cross dividers in height of 70 mm (base rack) and height of 34 mm (top frame)



Extender	Component height up to	Rack outer dimensions	Rack type*
155	155 mm	200 mm	PAD/155
170	170 mm	215 mm	PAD/170
185	185 mm	230 mm	PAD/185
200	200 mm	245 mm	PAD/200
215	215 mm	260 mm	PAD/215
230	230 mm	275 mm	PAD/230
Tube	customised in mm	customised in mm	PARD/...

\* Rack complete without cross and longitudinal dividers

## Base rack with side rail (open) and top frame with side panel (closed)

Longitudinal and cross dividers in height of 70 mm (base rack) and height of 34 mm (top frame)



Extender	Component height up to	Rack outer dimensions	Rack type*
155	155 mm	200 mm	PAE/155
170	170 mm	215 mm	PAE/170
185	185 mm	230 mm	PAE/185
200	200 mm	245 mm	PAE/200
215	215 mm	260 mm	PAE/215
230	230 mm	275 mm	PAE/230
Tube	customised in mm	customised in mm	PARE/...

\* Rack complete without cross and longitudinal dividers

Sizes  
400 x 300,  
400 x 400 and  
500 x 500 on  
request!

## The system components: Material Comp 13/14

The material type Comp 13/14 was designed for basic requirements in industrial component cleaning and is suitable for cleaning processes with aqueous and solvent-based media and ultrasound applications.

### tech-rack base rack

600 x 400 mm, outer rack height 110 mm  
can be used with side rail (open) or side panel (closed)



### tech-rack lid for base rack

600 x 400 mm, height 13 mm  
combinable with tech-rack variogrid



### Intermediate frame

600 x 400 mm, height 63 mm,  
for Custom rack or Clix rack



### Side strip

for securing of dividers  
RM 15 high



### Side panel

for securing of dividers  
RM 15 high and low

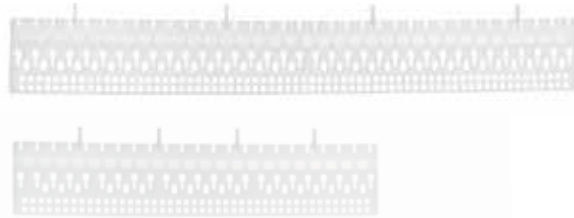

### Top frame low

600 x 400 mm, height 36 mm,  
for Custom rack or Clix rack  
combinable tech-rack variogrid



### Cross and longitudinal dividers high

RM 15 high  
Grid of 15 mm, height 70 mm

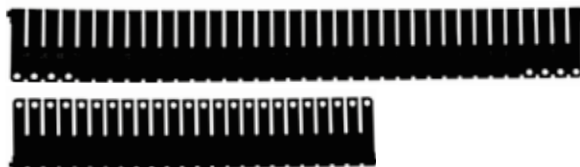

### Top frame high

600 x 400 mm, height 63 mm,  
for Custom rack or Clix rack  
combinable with tech-rack variogrid



### Cross and longitudinal dividers low

RM 15 low  
Grid of 15 mm, height 34 mm

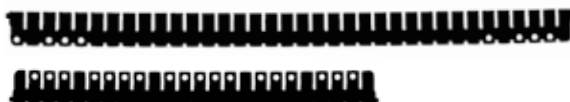

## The system components: Material Comp 21/22

The material type Comp 21/22 offers the advantage of even higher chemical and thermal resistance and meets higher requirements in industrial component cleani

### tech-rack base rack

600 x 400 mm, outer rack height 110 mm  
can be used with side rail (open) or side panel (closed)



### tech-rack cover for base rack

600 x 400 mm, height 13 mm,  
can be combined with the tech-rack variogrid, tech-rack custom



### Intermediate frame

600 x 400 mm, height 63 mm,  
for Custom rack or Clix rack



### Side strip

for securing of dividers  
RM 15 high

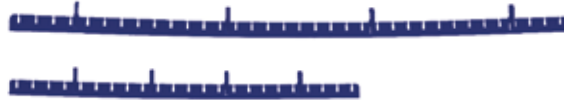

### Side panel

for securing of dividers  
RM 15 high and low



### Top frame low

600 x 400 mm, height 36 mm,  
for Custom rack or Clix rack  
combinable tech-rack variogrid



### Cross and longitudinal dividers high

RM 15 high  
Grid of 15 mm, height 70 mm

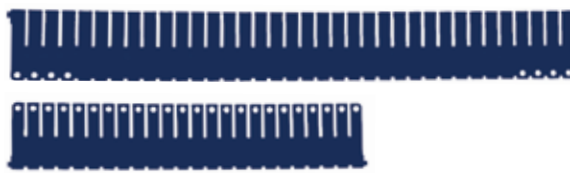

### Top frame high

600 x 400 mm, height 63 mm,  
for Custom rack or Clix rack  
combinable with tech-rack variogrid



### Cross and longitudinal dividers low

RM 15 low  
Grid of 15 mm, height 34 mm



## The system components: Accessories

### Tube extender for custom rack

for connection of base rack, intermediate frame and top frame. Tube can be individually adapted to the component height.



### Extender for Clixrack

connects the base rack, intermediate frame and top frame made from PA.



Extender	Component height up to
145	145 mm
155	155 mm
170	170 mm
185	185 mm
200	200 mm
215	215 mm
230	230 mm
245	245 mm

### Clix rack disassembly tool

for easy disassembly of Clix extender



### Extender for Clix rack

for connection of base rack, intermediate frame and top frame in Comp 21/22.



Extender	Component height up to
145	145 mm
155	155 mm
170	170 mm
185	185 mm
200	200 mm
215	215 mm
230	230 mm
245	245 mm

### Grid bottom for small parts

optional for small workpieces and bulk material, mesh width 3 x 3 mm (fine mesh)



# Uncomplicated and quick installation

»Individual, sustainable, safe«

The side rails and panels as well as cross and longitudinal dividers can be easily installed without tools. Disassembly and conversion can also be realised without any tools.

Side rail version

or

Side panel version

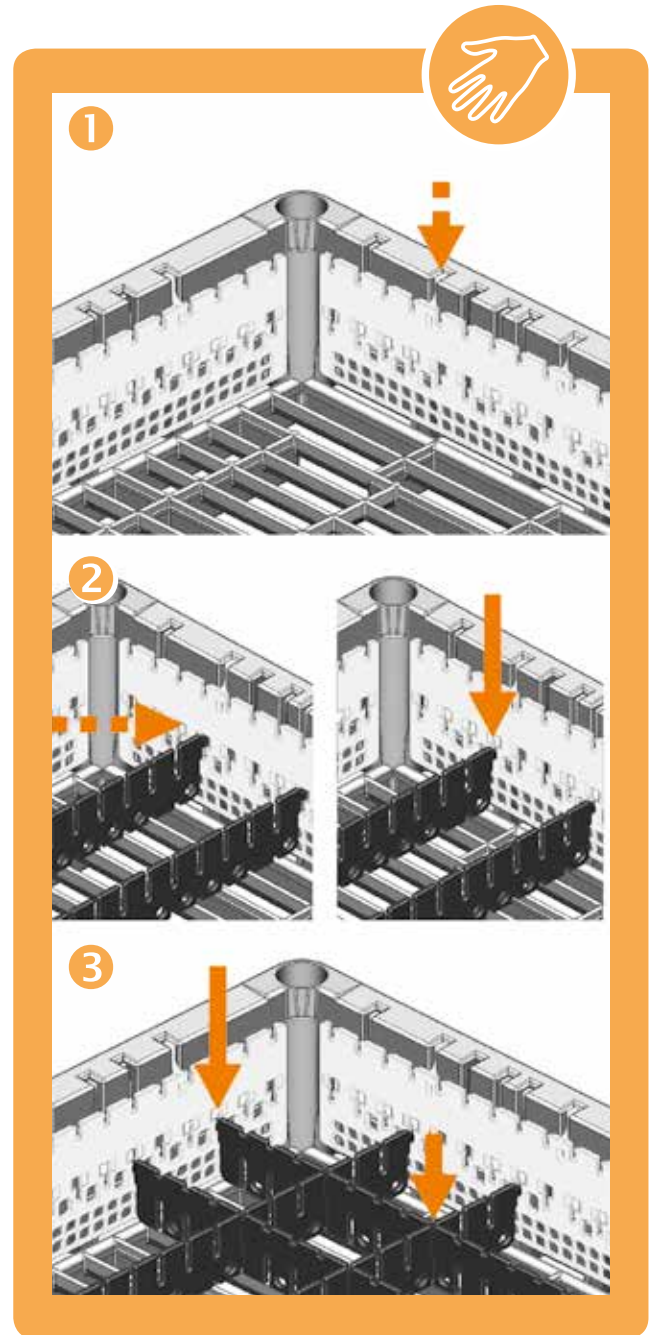
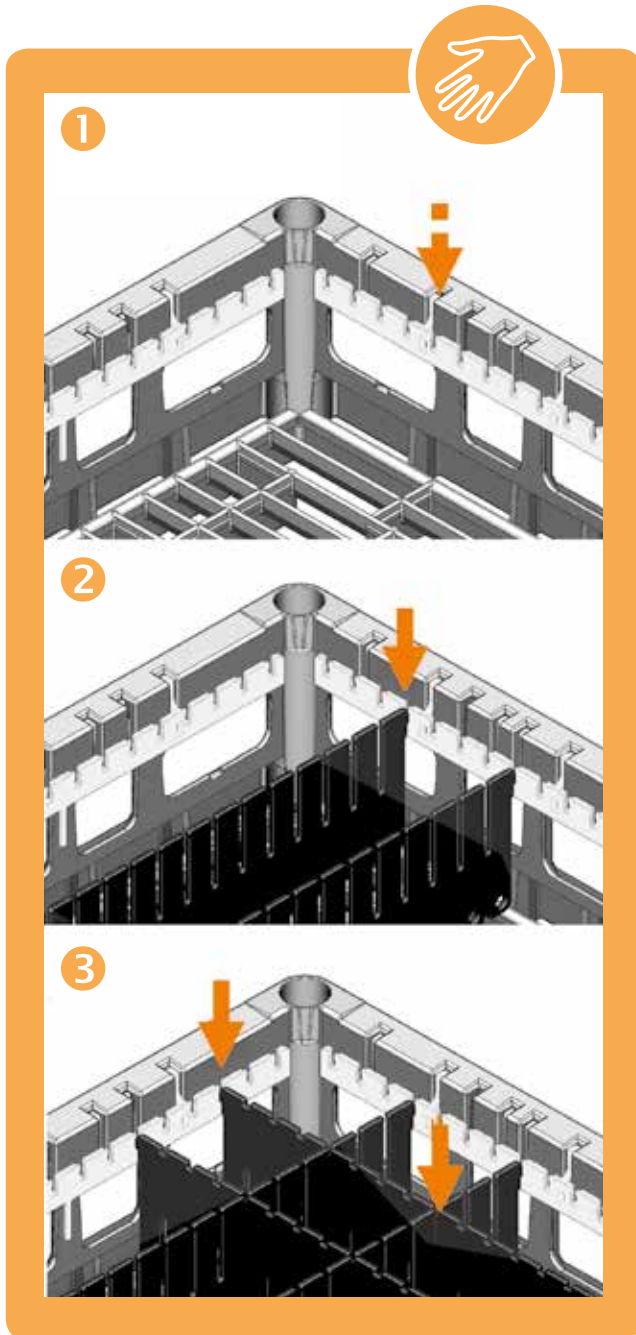

Identical installation also for top and intermediate frames.

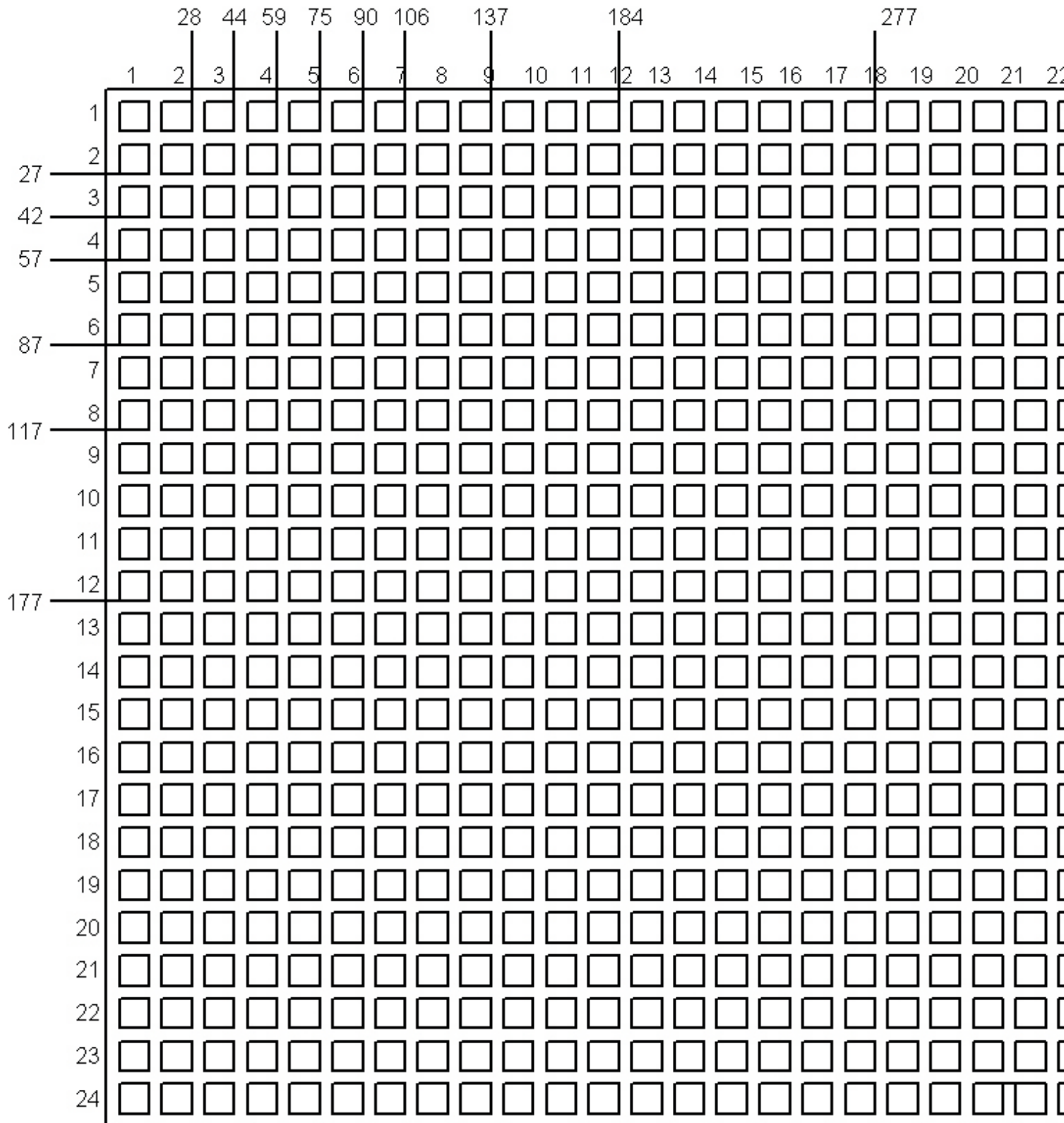

2 23 24 25 26 27 28 29 30 31 32 33 34 35 36

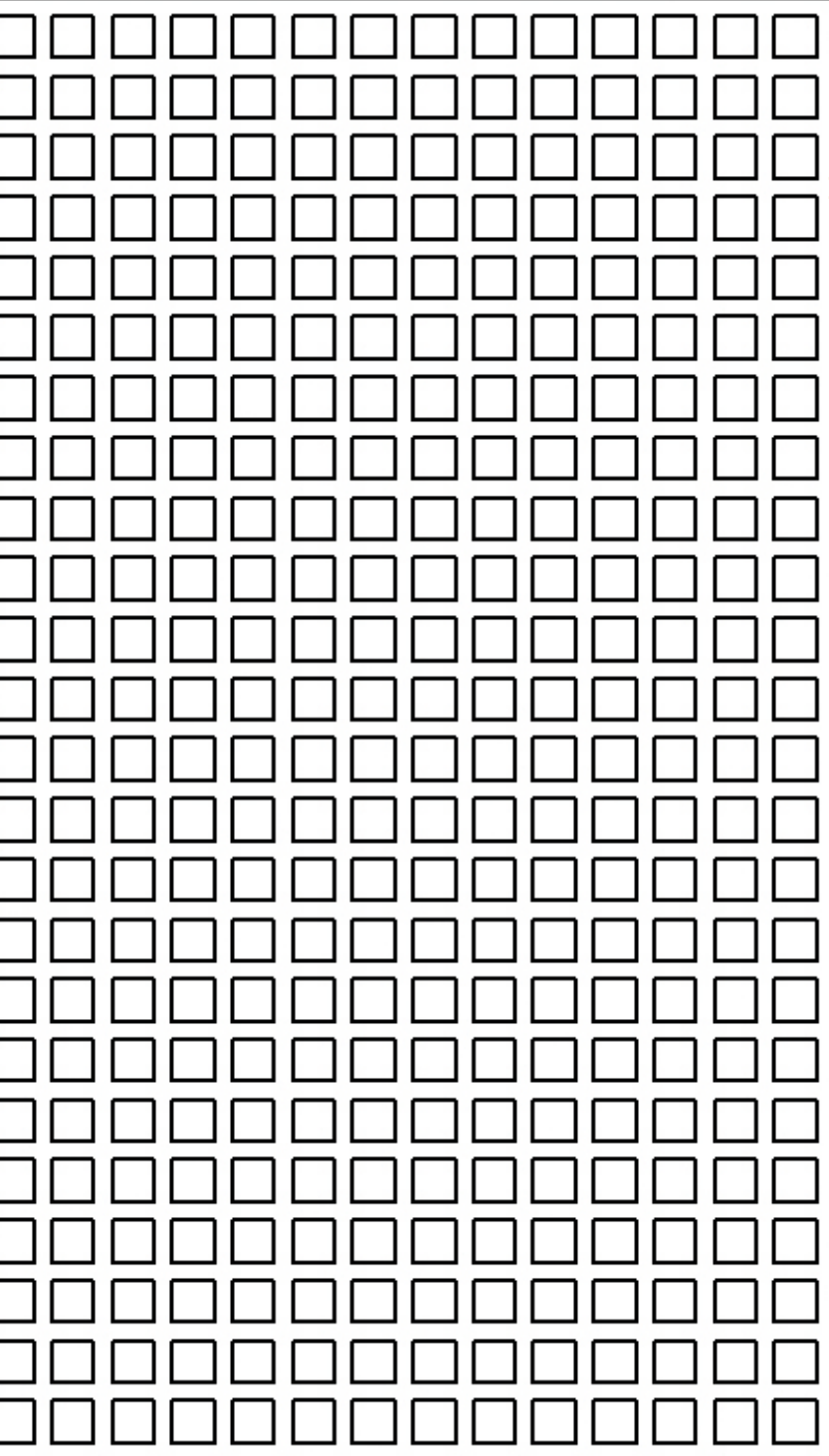

Divider strength  
= 3 mm

Not true to scale, dimensions in mm

# FRIES Kunststofftechnik

"Quality from Austria"

For generations, the core competence of FRIES Kunststofftechnik Ltd. has been in the development and production of high-quality plastic products. Particularly in the field of industrial cleaning of components, workpiece carriers and cleaning racks made of plastic offer numerous advantages in comparison with conventional metal grid racks.

Thanks to our thorough and efficient approach, short production times and highest quality standards, we will be able to realise all your projects: from prototyping over customer-specific development down to series production - everything from a single source. Without exceptions, all our products are produced at our company headquarters in Sulz, Austria.



Workpiece carrier systems  
All advantages at a glance  
[www.fries-kt.com](http://www.fries-kt.com)



## FRIES Kunststofftechnik GmbH

Schützenstrasse 19, 6832 Sulz, Austria  
Tel.: +43 5522 4935 201, Fax: +43 5522 4935 209  
info@fries.at, www.fries-kt.com



Sales partner



## Transoplast BV

Ulenpasweg 2, 7041 GB 's-Heerenberg, The Netherlands  
Tel. +31 (0)314 66 44 00  
website@transoplast.com, www.transoplast.com